

**Central Davis Sewer District**

# **Collection System**

# **Design Specifications**

**SECTION 02100  
SITE PREPARATION**

**PART 1 GENERAL**

1.1 WORK INCLUDED

- A. Preparation
- B. Clearing and grubbing
- C. Topsoil removal
- D. Asphaltic concrete pavement removal
- E. Portland cement concrete removal
- F. Removal of fences and miscellaneous obstructions
- G. Disposal of waste materials

1.2 QUALITY ASSURANCE

- A. All tree trimming and removal shall be done in accordance with recognized tree surgery standards.

**PART 2 PRODUCTS** Not Used

**PART 3 EXECUTION**

3.1 PREPARATION

- A. No clearing, demolition, or removal of any kind shall proceed until all existing trees, improvements, etc. to be removed have been established and are inspected and documented by the Owner.
- B. Establish necessary clearing limits within the construction limits. Mark all trees, shrubs, structures, fences, concrete, and other improvements to be removed.
- C. Within 10 feet of clearing limits, inspect, photograph with video, and record condition of concrete slabs, structures, landscaping and other features to remain which might be affected by work. Allow Owner to view video or pictures and approve prior to proceeding with the work.
- D. Trees, shrubs and lawn, areas to receive planting, rock outcroppings, fences, sprinklers and other improvements that are not to be removed shall be protected from damage or injury. If damaged or removed, they shall be restored or replaced in as nearly the original condition and location as is reasonably possible. Trees, shrubs, and improvements not to be removed shall be marked in field by Owner and/or shown on the drawings.
- E. Give reasonable notice to Owner to permit them to salvage plants, trees, fences, sprinklers and other improvements within the construction limits that may be destroyed because of the work.
- F. Notify interested utility companies to be present if disturbing ground in the vicinity of utilities.
- G. Protect active utility systems adjacent to or uncovered by any excavation during site preparation.

- H. Maintain benchmarks, monuments and other reference points and construction stakes.
- I. Protect all improvements to remain outside of construction from tree removal and/or pruning work.
- J. Schedule work carefully with consideration for property owners and general public.
- K. Provide temporary environmental controls for work.

3.2 CLEARING AND GRUBBING

- A. Remove all surface vegetation to a depth necessary for complete removal of all roots and other deleterious materials from within the areas to receive structural fill or base course.
- B. All trees, stumps, roots, etc. to be removed within the construction limits shall be cut off, excavated, or removed to a depth of not less than 3 feet below the existing ground.
- C. Branches of trees extending over the construction limits shall be trimmed to the boles to give a clear height of 20 feet above the existing ground surface. All trimming shall be done in accordance with recognized tree surgery standards. Remove additional tree branches under the direction of the Owner in such a manner that the tree will present a balanced appearance.

3.3 TOPSOIL REMOVAL

- A. Before any construction activity begins, remove topsoil to a maximum depth of 1 foot, unless otherwise required by individual property owner, and stockpile on the same property of which topsoil was removed. Stockpile where required by individual property owner.
- B. Topsoil shall be protected from contamination by weeds, debris, etc. and shall be replaced, graded and lightly compacted by Contractor at completion of project.
- C. Disposal of topsoil is not allowed.

3.4 ASPHALTIC CONCRETE PAVEMENT REMOVAL

- A. Sawing shall be used to ensure the breakage of pavement along straight lines.

3.5 PORTLAND CEMENT CONCRETE REMOVAL

- A. Concrete shall be removed to neatly sawed edges with saw cuts made to a minimum depth of 4 inches.
- B. Concrete sidewalk or driveway to be removed shall be neatly sawed in straight lines either parallel to the curb or at right angles to the alignment of the sidewalk. No section to be replaced shall be smaller than 30 inches in either length or width.
- C. Unless otherwise shown on the drawings, if the sawcut would fall within 30 inches of a construction joint, expansion joint, or edge, the concrete shall be removed to the joint or edge, except that where the saw cut would fall within 12 inches of a score mark, the saw cut shall be made in and along the score mark.
- D. Curb and gutter to be removed shall be sawed to a depth of 1-1½ inches on a neat line at right angles to the curb face.

3.6 FENCES AND MISCELLANEOUS OBSTRUCTIONS

- A. No demolition or removal of fences or miscellaneous obstructions shall proceed until clearance is obtained from the Owner.
- B. Prevent people or livestock from entering work site from adjacent properties during removal and installation procedures.
- C. Do not damage vegetation and ground cover during removal operations.

3.7 DISPOSAL OF WASTE MATERIALS

- A. Where salvage is not required as otherwise specified herein or as shown on the drawings, dispose of all removed materials at a suitable off-site location in accordance with applicable laws and ordinances.
- B. No burning shall be allowed.

**END OF SECTION**

**SECTION 02320  
EXCAVATING, BACKFILLING AND COMPACTION**

**PART 1 GENERAL**

1.1 WORK INCLUDED

- A. Preparation
- B. Excavation
- C. Backfilling
- D. Compaction
- E. Dewatering
- F. Field Quality Control
- G. Cleaning up

1.2 RELATED WORK

- A. Section 02590- Restoration of Existing Improvements
- B. Section 02535 Sanitary Sewer Systems

1.3 QUALITY ASSURANCE

- A. Comply with federal, state, and local codes and regulations.
- B. All working conditions shall be in accordance with the "Utah Occupational Safety and Health Division", Safe Practices for Excavation & Trenching Operations, latest edition, or other Laws or Regulations which apply.
- C. Prior to excavation, photograph existing surfaces along which work may take place in order to determine, after construction is completed, whether any damage to existing improvement occurred prior to construction operations.

1.4 REFERENCES

- A. Utah Occupational Safety and Health (UOSH).
- B. American Society of Testing Methods (ASTM):

- 1. Designation 01557.

1.5 SUBMITTALS

- A. Submit for approval drawings and structural calculations for trench shoring to be utilized.

1.6 QUALITY ASSURANCE

- A. Local jurisdiction requirements shall govern for all work in road rights-of-way:
  - 1. All work shall conform to the applicable standards, regulations, and requirements of the city or county for backfill and compaction above the pipe.
  - 2. Permits shall be secured from jurisdiction by the Contractor.

1.7 WARRANTY

- A. See Contract General Conditions for guarantee period.
- B. Any settlement noted in trench backfill or in structures built over the trench backfill will be considered to be caused by improper compaction methods and shall be corrected at no cost to the Owner.

1.8 SUBMITTALS

- A. If requested, submit all materials to Owner.
- B. Compaction tests as required by Owner, its agents or City with jurisdiction.

**PART 2 PRODUCTS**

2.1 FOUNDATION MATERIALS

- A. Sewer rock:
  - 1. Shall be hard, durable, broken stone or slag.
  - 2. Shall be graded within the following limits:

<u>Sieve Size</u>	<u>Percentage Passing By Weight</u>
2"	100
1"	85-100
1/2"	20-40
#4	10-20

2.2 BEDDING MATERIALS

- A. Gravel Bedding Material:
  - 1. Shall be free from alkali, salt, and petroleum products, roots, sod, limbs, and other vegetative matter, slag, cinders, ashes and rubbish, or other material that in the opinion of the Owner may be objectionable or deleterious.
  - 2. Graded within the following limits:

<u>Sieve Size</u>	<u>Percentage Passing By Weight</u>
1 1/2"	100
1"	95-100
1/2"	25-60
#4	0-10

2.3 BACKFILL MATERIALS

- A. Excavated Soil Backfill Material:
  - 1. Shall be free from alkali, salt, and petroleum products, roots, sod, limbs, and other vegetative matter, slag, cinders, ashes and rubbish, or other material that in the opinion of the Owner may be objectional or deleterious.

2. Shall be select material from excavation, with no particle larger than 3 inches in diameter.
  3. Use on-site materials only if specified compaction requirements can be met.
- B. Imported Backfill Material
1. If excavated material will not meet specified compaction requirements, import is to be used to meet jurisdictional requirements.
- C. Mirafi 140-N Filter Fabric.
- D. Locator Tape: Permanent bright colored, continuous-printed magnetic plastic tape, intended for direct burial service, not less than 6-inches wide by 4 mils thick. The tape shall read "CAUTION: BURIED INSTALLATION BELOW" and shall be colored green.
- E. 12-gauge copper tracer wire

### **PART 3 EXECUTION**

#### **3.1 PREPARATION**

- A. It shall be the Contractor's sole responsibility to locate all (whether or not shown on the Drawings) existing water, sanitary sewer, storm drain, and gas lines, electrical and telephone conduit and other underground utilities with their existing house service connections, and all other underground structures in order that no damage or loss of service will result from interference with existing lines.
- B. Review all available drawings, notes, and information on the location of these underground lines and structures in determining the location of the existing facilities.
- C. Have an electronic pipe finder on the job at all times and mark all lines on the road ahead of the excavating machine.
- D. Blue Stakes Location Center shall be contacted 3 business days before any excavation is commenced or as required by law. Phone 811 or 801-208-2100 for assistance.
- E. Mark with paint any existing cracks on concrete along which work will take place, in order to determine after the construction is completed whether such damage was caused by the operations of the Contractor or had occurred previously. Any concrete showing unmarked cracks upon completion of construction will be evidence of damage by the Contractor's forces, and shall be replaced or repaired to the satisfaction of the Owner of the damaged concrete, at the Contractor's own expense.
- F. All fences removed for excavation shall be returned to their original condition except that damaged portions will be replaced with new fencing at the Contractor's expense.
- G. Obtain all required permits.

#### **3.2 EXCAVATION**

- A. All gas, sanitary sewer, storm drain, water and other pipelines, flumes and ditches of metal, wood or concrete, underground electrical conduits and telephone cable, and all walks, curbs, and other improvements encountered in excavating trenches carefully shall be supported, maintained and protected from injury or interruption of service until backfill is complete and settlement has taken place.
- B. If any existing facility is damaged or interrupted, promptly after becoming aware thereof and before performing any Work affected thereby identify the owner of such existing facility, and give written notice thereof to that owner and the Owner. Comply with other applicable requirements of the General Conditions of the Construction Contract and indemnify the Owner from any and all damages

resulting from damaged facilities.

- C. Excavation for pipe lines, concrete valve boxes, manholes and appurtenant structures shall include the work of removing all earth, sand, gravel, quicksand, stone, loose rock, solid rock, clay, shale, cement, hardpan, boulders, and all other materials necessary to be moved in excavating the trench for the pipe; maintaining the excavation by shoring, bracing, and sheeting or well pointing to prevent the sides of the trench from caving in while pipe laying is in progress; and removing sheeting from the trench after pipe has been laid.
- D. The support system shall be suitable for the soil structure, depth of cut, water content of soil, weather conditions, superimposed loads, vibration. Contractor may select one of the following methods of ensuring the safety of workers in the trench, as approved by the Utah State Industrial Commission or its safety inspectors:
  - 1. Sloping sides of trench to the angle of repose at which the soil will remain safely at rest.
  - 2. Shoring trench sides by placing sheeting, timber shores, trench jacks, bracing, piles, or other materials to resist pressures surrounding the excavation.
  - 3. Using a movable trench box built-up of steel plates and a heavy steel frame of sufficient strength to resist the pressures surrounding the excavation.
- A. All damage, injury or loss resulting from lack of adequate sheeting, bracing, and shoring shall be the responsibility of the Contractor; and the Contractor shall effect all necessary repairs or reconstruction resulting from such damage.
- B. Trenches shall be of the necessary width for proper laying of pipe. Care shall be taken not to over excavate. The bottom of the trenches shall be accurately graded to provide uniform bearing and support for each section of the pipe along the entire length of the barrel of the pipe.
- C. Trenches shall be excavated to the depths shown on the Drawings, including any required allowances for the sewer rock foundation, when required, and for other pipe bedding requirements.
- D. The width of trench, measured at the top of the pipe, shall be as narrow as possible but not wider than 15 inches on each side of the pipe.
- E. Excavation for manholes, concrete boxes, clean outs and similar structures shall be sufficient to leave at least 12 inches in the clear between the outer surfaces and the embankment or timber that may be used to hold and protect the banks.
- F. Stockpile excavated material to cause a minimum of inconvenience to public and provide for emergency services as necessary.
- G. Excess materials shall be hauled away from the construction site or otherwise disposed of by the Contractor at an approximate disposal site.

### 3.3 BACKFILLING

- A. The trenches shall not be backfilled until the utilities systems as installed conform to the requirements of the Drawings and Specifications. Where, in the opinion of the Owner, damage is likely to result from withdrawing sheeting, the sheeting shall be left in place.
- B. Trenches shall be backfilled to the proper surface with material as shown or specified. Trenches improperly backfilled shall be reopened to the depth required for correction, then refilled and compacted as specified, or the condition shall be otherwise corrected as approved.
- C. Pipe Bedding - unless otherwise specified:
  - 1. Consists of preparing an acceptable pipe foundation, excavating the pipe groove in the prepared foundation and backfilling from the foundation to the top of the pipe. All piping shall be protected from lateral displacement and possible damage resulting from impact or unbalanced loading during backfilling operations by being adequately bedded.



2. Pipe foundation: Shall consist of 6 inches of Gravel Bedding material in the bottom of the trench. Wherever the trench subgrade material does not afford a sufficiently solid foundation to support the pipe and superimposed load, and where groundwater must be drained, the trench shall be excavated below the bottom of the pipe to such depth as may be necessary, and this additional excavation filled with sewer rock.
  3. A pipe groove shall be excavated in the pipe foundation to receive the bottom quadrant of the pipe so that the installed pipe will be true to line and grade. Bell holes shall be dug after the trench bottom has been graded. Bell holes shall be excavated so that only the barrel of the pipe bears on the pipe foundation.
  4. Pipe bedding from pipe foundation to the top of pipe: Deposition and consolidation of gravel bedding materials shall be done simultaneously and uniformly on both sides of the pipe. All bedding materials shall be placed in the trench with hand tools or other approved method in such a manner that they will be scattered alongside the pipe and not dropped into the trench in large quantities.
- D. Each lift shall be evenly spread and moistened or dried by disk harrowing or other means so that the required density will be produced.
  - E. Backfill around clean outs with Gravel Bedding Material.
  - F. Care shall be exercised so that when backfilling is complete and settlement has taken place, all existing pipes, flumes, ditches, conduits, cables, walks, curbs, and other improvements will be on the same alignment and grade as they were before work commenced.
  - G. Cut-off trenches may be required.
  - H. Install Mirafi 140-N filter fabric over gravel bedding material as required by jurisdictional authority.
  - I. Backfilling above pipe bedding is to be done per jurisdictional authority.
  - J. Install 12 gauge copper tracer wire over all sewer pipe.
  - K. Install locator tape 2 to 3 feet above pipe.

### 3.4 COMPACTION

- A. Compaction shall be the responsibility of the Contractor. He shall select the methods to be used and carefully perform the work of backfilling and compaction to prevent damage to new or existing piping. Any new or existing piping damaged during the Contractor's work shall be replaced as directed by the Engineer with new piping.
- B. Backfill Compaction Requirements - unless otherwise specified by local jurisdictions, comply with the following:
  1. Under pavements, or other surface improvements, the minimum density shall be 96% of laboratory maximum density, as determined by ASTM Designation D-1557.
  2. Unimproved areas, the minimum density shall be 85% of laboratory maximum density, as determined by ASTM Designation D-1557.
  3. Landscaped areas, the minimum density shall be 90% of laboratory maximum density as determined by ASTM 0-1557.
- C. Method of compaction include mechanical compaction (MC) only. Authorization by the Owner to use any method does not relieve the Contractor of his responsibility to meet the specified density requirements. Compaction shall be performed in strict accordance with the manufacturer's recommendations for each type of pipe.

- D. Mechanical compaction: Shall be accomplished by the use of sheepsfoot rollers, pneumatic tire rollers, vibrating rollers, or other mechanical tampers of a size and type necessary to achieve the required degree of compaction.
- E. Water jetting shall not be allowed.

3.5 DEWATERING

- A. The Contractor shall do all pumping, shall build all drains and do all the work necessary to keep the trench and pipes free from water during the progress of the work.
- B. In wet trenches, a channel shall be kept open along the side of the pipe for conducting the water to a sump hole, from which it shall be pumped out of the trench. No water shall be allowed to enter the pipe.

3.6 FIELD QUALITY CONTROL

- A. The Owner will employ a testing laboratory to perform field and laboratory density tests as specified in the pipe zone. Provide access to the work and all men and machinery necessary to aid the testing laboratory personnel in performing field density tests or taking samples for laboratory tests. In general, tests and samples shall be made as the work proceeds. The Contractor shall cooperate with the Owner to schedule and perform tests.
- B. The Owner will direct testing laboratory to perform maximum density tests on materials to be compacted from samples submitted by Contractor taken from locations selected by the Engineer.
- C. The Owner will direct testing laboratory to perform field density tests of compacted backfill materials. The approximate location and number of such tests shall be as shown on the drawings, or as selected by the Owner. Field density tests shall be taken as follows, or as otherwise selected by the Owner:
  - 1. In planted or unimproved areas:
    - (a) 18" above the top of the pipe
    - (b) Finished grade
  - 2. In streets, roads, parking lots or other paved areas:
    - (a) 18" above the top of the pipe
    - (b) 24" to 36" below the gravel road base
    - (c) Gravel road base subgrade
    - (d) Top of gravel road base
    - (e) Top of bituminous surface course
- D. Copies of test results prepared by the testing laboratory will be transmitted to the Contractor at the same time they are transmitted to the Owner.
- E. Successful performance of field density tests by the testing laboratory shall not relieve the Contractor of his responsibility to meet the specified density requirements for the complete project.
- F. Additional tests shall be made on samples taken from locations selected by Owner.
- G. Additional testing, due to failure, shall be performed at no additional cost to the Owner.

3.7 CLEANING UP

- A. The roadway including shoulders, slopes, ditches, and borrow pits shall be smoothly trimmed, and shaped by machinery, or other satisfactory methods, to the lines, grades and cross-sections, as established, and shall be so maintained until accepted. Any surplus material not suitable for spreading along the road to widen the existing shoulder or raise the grade shall be hauled away or disposed of at a suitable site.

**END OF SECTION**

**SECTION 02535  
SANITARY SEWER SYSTEM**

**PART 1 GENERAL**

1.1 WORK INCLUDED

- A. Furnishing and installation of pipe, fittings, manholes, and service laterals
- B. Adjust existing sewer manhole rings to proper finish grade.
- C. Pressure test the lines, including flushing and cleaning.

1.2 RELATED WORK

- A. Section 02320 Excavating, Backfilling, and Compaction
- B. Section-02590- Restoration of Existing Improvements

1.3 QUALITY ASSURANCE

- A. Workmanship and methods employed in the handling, transportation, storage, bedding, and laying of pipe, fittings, associated structures and accessories shall conform to the appropriate manufacturers' recommendations and/or ASTM recommendations

1.4 SUBMITTALS

- A. Submit manufacturer's specifications for all products.
- B. As constructed locations of all wyes, cleanouts and covered fittings shall be prepared by the contractor and submitted to the Owner.

1.5 DELIVERY AND HANDLING

- A. Load and unload pipe, fittings, and accessories in such a manner as to avoid shock or damage.

1.6 SANITARY SEWAGE PIPING DEPTH

- A. Unless arrangements have been made otherwise with the owner, the depth of sanitary sewage piping in subdivisions should not exceed 12 feet. If approval is obtained from Central Davis Sewer District (CDS or District) for deep sewer, specialty sewer pipe such as green C900 DR-18 or a District approved alternative will be used.
- B. The minimum allowable depth of cover on sewer lines is 42 inches.

**PART 2 PRODUCTS**

2.1 SANITARY SEWER PIPING

- A. Concrete pipe shall meet the requirements of ASTM C-14, Class III, with push-on gasket joints conforming to ASTM C-443. Cement for the pipe shall be Portland Cement, Type V, conforming to ASTM C-150.
- B. PVC (polyvinyl chloride) shall meet the requirements of ASTM 03034 for SDR 35. The pipe shall have integral wall bell and spigot joints conforming to ASTM D-3212, with a solid cross-section rubber ring, factory assembled, securely locked in place to prevent displacement during assembly. The pipe shall be colored green for in-ground identification as sewer pipe.

- C. C900 DR-18 shall meet the requirements of ASTM D 1784.
- D. Schedule 80 PVC (polyvinylchloride) shall meet the requirements of ASTM D 1785 and shall have solvent welded joints.
- E. Each separately owned single use parcel shall be served with an individual sanitary sewer service line. Each separate sanitary sewer service line shall be connected to the District's main line. One sanitary sewer line connection will be allowed to serve one parcel.

## 2.2 MANHOLES

- A. Manholes shall be 48 or 60 inches in diameter conforming to ASTM C-478 with a 48"x30"x3' concentric cone section.
- B. Manholes shall be watertight, both in the floor and the full height of the walls.
- C. Manholes may be precast, including the base section, standard sections and grade rings.
- D. Cement for manholes shall be Portland Cement, Type V, or Type II-A complying with ASTM C-150.
- E. Joints shall be made tight by the use of Kent-seal or equal.
- F. Manhole Ring & Cover: Gray Iron castings conforming to ASTM A-48, Class 30, with non-rocking, machined bearing surfaces between cover and frame.
  - 1. Cover with lettering "SEWER" or "CENTRAL DAVIS SEWER"
  - 2. Lid shall be non-vented.
  - 3. Manhole grade rings shall be nominal 30 inch- diameter conforming to ASTM C-478 for concrete sewer manholes.
  - 4. Rings and cover shall weigh not less than 350 pounds and covers shall be solid.
  - 5. FLAT LIDS will not be allowed, a minimum 4 inches of concrete will be required for the concrete collar.
- G. Flexible Pipe Connector: conform to ASTM C-923 size specifically for type and size of pipe.
- H. No steps in manholes.
- I. For Drop- Manholes stainless steel anchor straps: One piece, 50% circumferential cradle support with neoprene line to isolate and protect pipe. All metal items shall be stainless steel. Standen Model S36 as manufactured by Material Resources Inc. or approved equal.

## 2.3 CAST-IN-PLACE CONCRETE

- A. Cement shall be Type II-A or Type V complying with ATSM C-150
- B. Coarse Aggregates shall conform to ATSM C-33 using 3/4 inch course aggregate size and 3/8 inch minus fine aggregate size.
- C. Air entraining agent shall conform to ASTM C-175 and added at the mixer.
- D. Concrete mix shall be 6.5 sacks/cubic yard; 4000 psi 28 day compressive strength; 4 inch maximum slump and 5 to 6.5% air entrainment.

### **PART 3 EXECUTION**

#### **3.1 PREPARATION**

- A. When connections are to be made to any existing pipe, conduit, or other improvement, the actual elevation or position of which cannot be determined without excavation, the Contractor shall excavate for and expose the existing improvement before laying any pipe.
- B. Preliminary Qualifying Test: If required by the Owner, the first section of pipe not less than 300 feet in length installed by each crew shall be tested in order to qualify the crew and/or material. Successful installation of this section shall be a pre-requisite to further pipe installation by said crew.

#### **3.2 PIPE INSTALLATION**

- A. Bedding:
  - 1. Bedding shall be prepared in accordance with Section 02320 Excavating, Backfilling and Compaction and as shown on the plans.
  - 2. Lay all pipes on a firm bed, true to the line and grade, and abut the end and shoulder of each pipe against the other in such a manner that there is no unevenness of any kind along the bottom half of the pipe line.
- B. During all phases of pipe installation, dewater trench to prevent floating of pipe.
- C. Lay pipe in the uphill direction with the bell end pointing upgrade.
- D. Manufacturer's recommendations: Perform all work in strict accordance with the manufacturer's recommendations for the type of pipe being installed.
- E. Clean pipe joints prior to installing. Install pipes in accordance with manufacturers' recommendations.
- F. Where water lines are parallel to sewer lines, state requirements must be met. The separation requirements can be found with the division of Utah Drinking Water.
- G. Where water lines cross sewer lines, maintain a minimum vertical separation of 18 inches with the sewer line below the water line. Where this separation is impossible, a twenty-foot length of PVC or D.I. pipe shall be used centered under the water line so as to have no joints within 10 feet of the crossing. Any joints within the 10-foot crossing shall be of the solvent weld type. As required by the division of Utah Drinking Water.
- H. Take care to avoid contact between the pipe and compaction equipment. Compaction of bedding and backfill material should generally be done in such a way so that compaction equipment is not used directly above the pipe until sufficient backfill has been placed to ensure that such compaction equipment will not have a damaging effect on the pipe.
- I. Pipe transition into manhole must be smooth and free of any pockets, or indentations.
- J. Grade changes through manholes must be 2% or less, unless authorized by District Manager.
- K. Grouting in the joint area may be required as directed by the owner.
- L. No acute angles between pipes.
- M. Utility Crossings with less than 18 inches of clearance are prohibited unless approved by the District. In cases where approval is granted, concrete pier supports for crossing pipeline will be required.
- N. Per State Code R317 sewer lines shall not be longer than 400 feet without a manhole.

- O. Pipes less than 8 inches in diameter are not allowed to connect on to a major trunk line.
- P. Trench plugs are required before connecting to the existing sewer lines.
- Q. Concrete Inserta Tees are required for laterals connecting to specialty sewer pipe.
- R. Sewer line slopes must meet the following requirements:

<u>Pipe Diameter (inches)</u>	<u>Slope (%)</u>
8	0.5
10	0.4
12	0.31

\* Sewer lines greater than 8 inches in diameter require District Manager approval. Slopes for sewer lines greater than 12 inches will be up to the District Manager's discretion, however, compliance with State code is mandatory.

### 3.3 MANHOLES

- A. Excavation, bedding and backfill for manhole installation shall be in accordance with Section - 02320 Excavating, Backfilling and Compaction.
- B. Construct the manhole at the specific stations and grades shown on the Drawings.
- C. Set manholes so that the top of the manhole lid is level with the finished surface or grade.
- D. Cast-in-place base and floor shall conform with requirements of standard details for layout and configuration.
- E. Cast Manhole bases with at least 80 percent of full diameter below skirt/shelf.
- F. All lifting holes must be grouted watertight.
- G. All Drop Manholes must be approved by the District. Outside Drop Manholes are not allowed.

### 3.4 GREASE INTERCEPTORS

- A. Grease Interceptors are required for all food establishments. No food establishments will be allowed into new and existing facilities without a grease interceptor.
- B. Grease Interceptor calculation must be submitted to the District to determine the size of the required grease interceptor. The minimum size of a grease interceptor is 750 gallons.

### 3.5 CASING

- A. Wastewater lines shall be installed inside casings when additional protection of the line is necessary as determined by CDSD.
- B. Casings shall meet the requirements of the applicable City, County or State standards.
- C. As a minimum, casings shall be steel pipe conforming to ASTM A 139, Grade A. Alternate casing pipe material may be allowable, as approved by CDSD.
- D. Joints between sections of casing pipe shall be welded around the full circumference to provide a water-tight joint.

### 3.6 CLEANING AND FLUSHING OF SANITARY SEWER LINES

- A. Thoroughly clean all pipe lengths or units laid of all debris immediately after laying.
- B. At the end of the day's lay, or at any time the work is closed down for any reason, plug open ends of the pipe to prevent the entrance of small animals and foreign material of any kind into the pipe.
- C. Thoroughly clean by flushing, capturing and removing all debris from sewer mains.
- D. Do not discharge flushing water down the sewer pipe. Must capture and dispose of cleaning water.

3.7 INSPECTION, CLEANING AND PROTECTION

- A. Inspect and clean all lines as specified hereinbefore.
- B. Video all sewer lines using camera equipment specifically designed for use in sewer lines.
- C. Two TV logs are required to be submitted to the District, one after construction and another after asphalt paving.
- D. Present video to Owner in an acceptable format. Data recorded on video shall have the following information:
  - 1. Date
  - 2. Time of day
  - 3. Distance in feet along pipe reach camera has traveled.
  - 4. Map detailing the location of the sewer lines on the video.

3.8 FINAL INSPECTION

- A. The final inspection is to be completed after the final road surfacing. When the final road surfacing has been completed, the Applicant is responsible to contact District personnel for a final inspection. Prior to this final inspection, the following items shall be completed:
  - 1. All manholes shall be uncovered and raised to grade
  - 2. District approved covers shall be installed on all manholes.
  - 3. All manholes and sewer lines shall be clean and free of debris; final TV inspections shall be submitted to the District.

3.9 ACCESS

- A. A 12' all-weather access road is required to access all manholes not located in the Right of Way. An all-weather surface is defined as 4 inches of asphalt or 6 inches of concrete.
- B. Sewer lines not located in the Right of Way shall be constructed of C900 green pipe or authorized pipe as approved by the District.
- C. All sewer lines must be stubbed to the property line to allow access to other developing properties.
- D. The turn around radiuses must be met for a Vactor 2100i series.



3.10 EASEMENTS

- A. All sewer lines and manholes not located in the public Right of Way will require a minimum 30' sewer easement, with a minimum of 15' on each side of the sewer line. An easement greater than 30' may be required depending on the location, size of sewer line and depth of the sewer line by the District Manager.
- B. All easements are required to be recorded in District Language and on the Plat with the book and page. Prior to recording, easements must be submitted to the District for review.

**END OF SECTION**

**SECTION 02540  
LOW HEAD SEWER**

**PART 1 GENERAL**

**1.1 WORK INCLUDED**

- A. Furnishing and installation of low pressure sewer main.
- B. Furnishing and installation of Manhole connections
- C. Furnishing and installation of combination air valve.
- D. Furnishing and installation of on line flushing connection.
- E. Furnishing and installation of private lateral assembly.
- F. Furnishing and installation of pump assembly.
- G. Pressure testing of lines including flushing and cleaning.

**1.2 RELATED WORK**

- A. Section 02320 Excavating, Backfilling, and Compaction
- B. Section 02535 Sanitary Sewage Systems
- C. Section 02590 Restoration of Existing Improvements

**1.3 QUALITY ASSURANCE**

- A. All work is to be done in accordance with Manufacturer's recommendations

**1.4 SUBMITTALS**

- A. Public Wastewater System design shall avoid Low-Pressure Sewer Systems. CDSD permits the construction of Low-Pressure Sewer Systems as part of the Public Wastewater System only under certain limited conditions. Gravity flow sewer systems must be utilized until they can no longer meet the required specifications.
- B. If the use of a Low-Pressure Sewer System is approved by CDSD the following requirements shall be met.
  - 1. Notes concerning the Low-Pressure Sewer System shall be included on the subdivision plat for the project as described in Section 1.4(H).
  - 2. A Notice shall be recorded against each lot served by the Low-Pressure Sewer System which will serve as notification to all future lot owners of the responsibilities associated with the Private Lateral Low-Pressure Wastewater Lines.
  - 3. The Low-Pressure Sewer System shall meet the requirements of these CDSD Standards.
- C. Manufacturer's specifications for all products.
- D. Manufacturers shall be approved by District.
- E. Submit manufacturers design recommendations:
  - 1. Manufacturers design recommendations and calculations:

- (a) Pipe sizing
  - (b) Retention time
2. Design calcs and recommendations should be based on the following criteria:
- (a) Minimum velocity = 2 feet per second
  - (b) Total dynamic head = 138 feet
  - (c) Flow rate per core(pump) = 11 gpm
  - (d) Minimum pipe size = 1 ½ inch
  - (e) Desired detention time = less than 24 hours
- F. As constructed locations of all wyes, fittings, flushing connections, corporations stops, and air valves shall be submitted in GPS format and on Central Davis Sewer District control.
- G. The following information will be required on the plans for District approval of the low-pressure sewer system:
- 1. Number Of Units Connected To The Low-Pressure Sewer System
  - 2. Design Maximum Flow
  - 3. Pipe Size
  - 4. Design Velocity And Design Maximum Flow
  - 5. Friction Losses
  - 6. Static (Elevation) Head
  - 7. Total Head
  - 8. Anticipated Number Of Simultaneous Pump Operations
  - 9. Depth And Elevations Of Low-Pressure Sewer System
  - 10. Proximity To Other Utilities
  - 11. Pipe Material
- H. The following information will be required on the plat:
- 1. Lots are designated as Low-Pressure Sewer System Lots. The purchasers of these lots are hereby notified that wastewater service to these lots will be provided by a Low-Pressure Sewer System. The Private Low-Pressure Sewer Lateral to these lots consists of a Low-Pressure grinder pump station and Low-Pressure discharge line and appurtenances. The Private Low-Pressure Lateral System, which is the private property of each lot owner, connects to the Central Davis Sewer District's (CDSD) Public Low-Pressure Sewer System. Purchasers of the Low-Pressure Sewer System Lots shall be solely responsible for all costs of the Private Low-Pressure Lateral System related to or arising from the installation, operation, maintenance, repair and replacement of the Private Low-Pressure Sewer Lateral System. CDSD shall have no liability or responsibility for Private Low-Pressure Sewer Lateral Systems, including any costs arising from or relating to installation, operation, maintenance, repair and replacement and matters arising from freezing or incorrect installation.

2. Upon recordation of this plat, (owner noted on plat) hereby consents and authorizes Central Davis Sewer District to record a notice for each Low-Pressure Sewer System Lot with the Davis County Recorder's Office. The recorded notices shall serve as notification to all future lot owners of the responsibilities associated with the Private Low-Pressure Sewer Lateral System serving the lots.
3. Other Low-Pressure Sewer System notes specific to the project as required.

1.5 DELIVERY AND HANDLING

- A. Delivery and handling shall be per the manufacturer's recommendations.

**PART 2 PRODUCTS**

2.1 LOW PRESSURE SEWER PIPE

A. High Density Polyethylene (HDPE) Pipe

1. Materials: Virgin resins, Cell Classification meeting or exceeding PE 345434C as defined in ASTM D 3350, resins shall be listed by the Plastic Pipe Institute in its pipe grade registry TR-4.
2. Pipe and Fittings:
  - (a) ASTM Material Designation Code: PE 3408 high density, extra high molecular weight.
  - (b) 1 1/2" thru 12" diameters. SOR and Pressure Class shall be based on specific requirements of installation with minimum SOR 11 and Pressure Class 160 in accordance with ASTM F 714.
  - (c) Outside diameter to be ductile iron pipe size (DIPS) or iron pipe size (IPS).
  - (d) Marked in accordance with ASTM F 714.
  - (e) Pipe shall be manufactured with an integral color coded stripe of HOPE, color green.
3. Joints: Zero leak-rate heat-fusion joint conforming to ASTM D 3261.
4. Thrust blocking: appropriate thrust blocking, designed specifically for the pressures and soil conditions encountered, shall be installed at all fittings.
5. Air testing is required for all HDPE pipe, per manufacturers recommendation.

B. Polyethylene Tubing

1. Pipe for the transmission of irrigation water from main to utility box shall be Polyethylene IPS tube. Polyethylene IPS tube shall be manufactured in accordance with the standard specification for Polyethylene (PEP plastic tubing as issued by the American Standard for Testing and Materials under ASTM D 2737 and AWWA C-901.)
2. Pipe and Fittings:
  - (a) Polyethylene PE 3408
  - (b) Elastic Extrusion Compound: Type III, Class C, Grade 34, as defined in ASTM D 1248

- (c) Standard pipe dimension ratio IPS (SDR) 9 - 200 PSI pressure rating
- (d) All tubing for service lines shall be cut and installed in a neat and workmanlike manner by a method recommended by the manufacturer.
- (e) Tubing shall be WESTFLEX PE 3408 Gold Label or equivalent
- (f) On IPS pipe, all fittings are brass Ford compression or similar with stainless steel insert to fit size of pipe.

2.2 MANHOLES

- A. Manholes are to meet the requirements of Section 02730, Sanitary Sewage Systems.

2.3 COMBINATION AIR VALVE

- A. Sewage Combination Air Release and Air/Vacuum Valve with Accessories:
  - 1. ValMatic Series 800 as manufactured by ValMatic Valve and Manufacturing Company or approved equal.
  - 2. Miscellaneous Pipe and Fittings: Threaded, schedule 40 brass.
- B. Universal Coupling: 316 stainless steel, 110 psi working pressure. Air King Universal Coupling as manufactured by Dixon Valve and Coupling Co. or approved equal.
- C. Ball Valve: Nickel-plated brass body with Type 316 stainless steel ball and stem, full port, vinyl coated steel lever-style handle, threaded, minimum 150 psi working pressure. The size of the in-line valve shall match the main line.

2.4 FLUSHING CONNECTION

- A. Ball Valve: Nickel-plated brass body with Type 316 stainless steel ball and stem, full port, vinyl coated steel lever-style handle, threaded, minimum 150 psi working pressure. The size of the in-line valve shall match the main line size. Flushing connection shall be 2" or 1- 1/2 ".
- B. Valve Box - traffic rated iron with lid stamped "SEWER".

2.5 PRIVATE LATERAL WASTEWATER LINE

- A. Individual low pressure grinder pump station: Environmental One GP2000 series as manufactured by Environmental One Corporation or equal.
- B. Private Lateral Components:
  - 1. Combination curb stop valve/check valve assembly with valve box: Engineered Thermoplastic Service Lateral Components of pipe as manufactured by Environmental One Corporation or equal.
  - 2. Valve box shall be polypropylene extension type with arch pattern base.
  - 3. Valve boxes shall include valve operator extension rod.
- C. Pipe Supports:
  - 1. Saddle Clamp Support: Two piece, full circle saddle clamp support with neoprene liner to isolate and protect pipe. All metal items shall be stainless steel. Standon Model C92 as manufactured by Material Resources Inc. or approved equal.

### **PART 3 EXECUTION**

#### **3.1 PIPE INSTALLATION**

- A. Conform to all requirements of Section 02535 Part 3.
- B. Comply with specific requirements of pipe manufacturer.
  - 1. PVC Pipe: ASTM D 2321 "Standard Recommended Practice for Underground Installation of Flexible Thermoplastic Sewer Pipe".
  - 2. High Density Polyethylene (HDPE) Pipe: ASTM D 2321 "Standard Recommended Practice for Underground Installation of Flexible Thermoplastic Sewer Pipe".
- C. Place marking tape directly above the pipe along the entire length.

#### **3.2 MANHOLES**

- A. Comply with requirements of Section 02535 Part 3.03
- B. As a minimum, the Low-Pressure sewer is to be stubbed to match the top of gravity pipe.
- C. Provide drop channel that is 6" above gravity pipe flowline for Low pressure sewer.
- D. For drop connection with low pressure sewer and manhole provide:
  - 1. Drop channel that is 6" higher than flow line at gravity line
  - 2. Secure low-pressure sewer drop line with stainless steel anchor straps placed 24 inches on center. Fasten straps to manhole wall to withstand a standard pull test.
  - 3. Glue or fuse all fittings and joints on drop connection.

#### **3.3 COMBINATION AIR VALVE**

- A. Approval of air valves location required prior to construction.
- B. Install at system high points, significant grade changes.
- C. In long horizontal runs that lack clearly defined high points, install at intervals of 2000 feet.
- D. Manholes that house air valves follow requirements of Section 02535.
- E. Size air valves for the specific location and system configuration.
- F. Test Air Valves system to withstand psi pressure at 200 psi.
- G. Install air valve at beginning of each downward leg that exhibits a 30 foot or more drop.

#### **3.4 FLUSHING CONNECTION**

- A. Install at terminal end of each main line, wherever two or more main lines come together, and other locations determined by District.
- B. Provide and size thrust blocks to hold pipe in place at 200 psi operating pressure.
- C. Flushing connections shall be installed at 400-foot intervals with the main line. Spacing is determined between terminal connection and tie-in manhole.

3.5 MONUMENTS

- A. Monuments are required wherever two or more main lines come together, and other locations determined by District, where installing a monument is more practical than a flushing connection.
- B. Locator Balls are required in each Monument. Locator Balls can be obtained from the District.

3.6 PRIVATE LATERAL

- A. Install lateral per manufacturer requirements and in accordance to Detail 307.
- B. Locate lateral away from driveways, and from beneath any pertinent structures.
- C. Locate curb stops valve assembly and box withing 1 to 3 feet of front property line.
- D. Curb box is to be adjusted so lid is at finished grade.
- E. Place 2 foot by 4 foot marker at end of lateral and extends 3 feet above ground.

3.7 CLEANING AND FLUSHING

- A. Thoroughly clean all pipe of debris immediately after laying.
- B. At the end of day's lay, or at any tie the work is closed down for any reason, plug all open ends of the pipe prevent entrance of small animals and foreign materials of any kind onto the pipe.
- C. Thoroughly clean by flushing and remove all debris from sewer lines. System is rated to handle 150 psi. DO NOT exceed pressure rating when flushing the system.

**END OF SECTION**

**SECTION 02590  
RESTORATION OF EXISTING IMPROVEMENTS**

**PART 1 GENERAL**

1.1 WORK INCLUDED

- A. Construction or repair of fences, driveways, walls, landscaping, roadways, curbs, sprinkler systems, walks or any other structure or improvement (surface or sub-surface) removed or damaged pursuant to completing the contract requirements.

1.2 QUALITY ASSURANCE

- A. Use adequate number of skilled workmen who are trained and experienced in the type of construction required.
- B. The quality of the finished restored improvement, as determined by the Owner, shall be of equal or better quality than was said improvement prior to being damaged or removed.

**PART 2 PRODUCTS**

2.1 MATERIALS

- A. As required to complete the restoration of existing improvements.
- B. At least equal to original improvement at the time of damage or removal, as determined by the Owner, and matching in finish and dimension.
- C. Shall be in accordance with requirements for governing municipality

**PART 3 EXECUTION**

3.1 PREPARATION

- A. Protect all public and private property adjacent to the work. Exercise due caution to avoid damage to such property.

3.2 RESTORATION

- A. Repair or replace all existing surface and subsurface improvements, which were damaged or removed as a result of operations of work under this contract. In roads and driveways, the restored surface and base courses shall be to thicknesses directed by local jurisdiction or at least equal in thickness to the existing.
- B. Restoration shall be of at least equal quality and identical in dimension to original improvement unless specifically specified otherwise or required by local jurisdiction having authority.

**END OF SECTION**



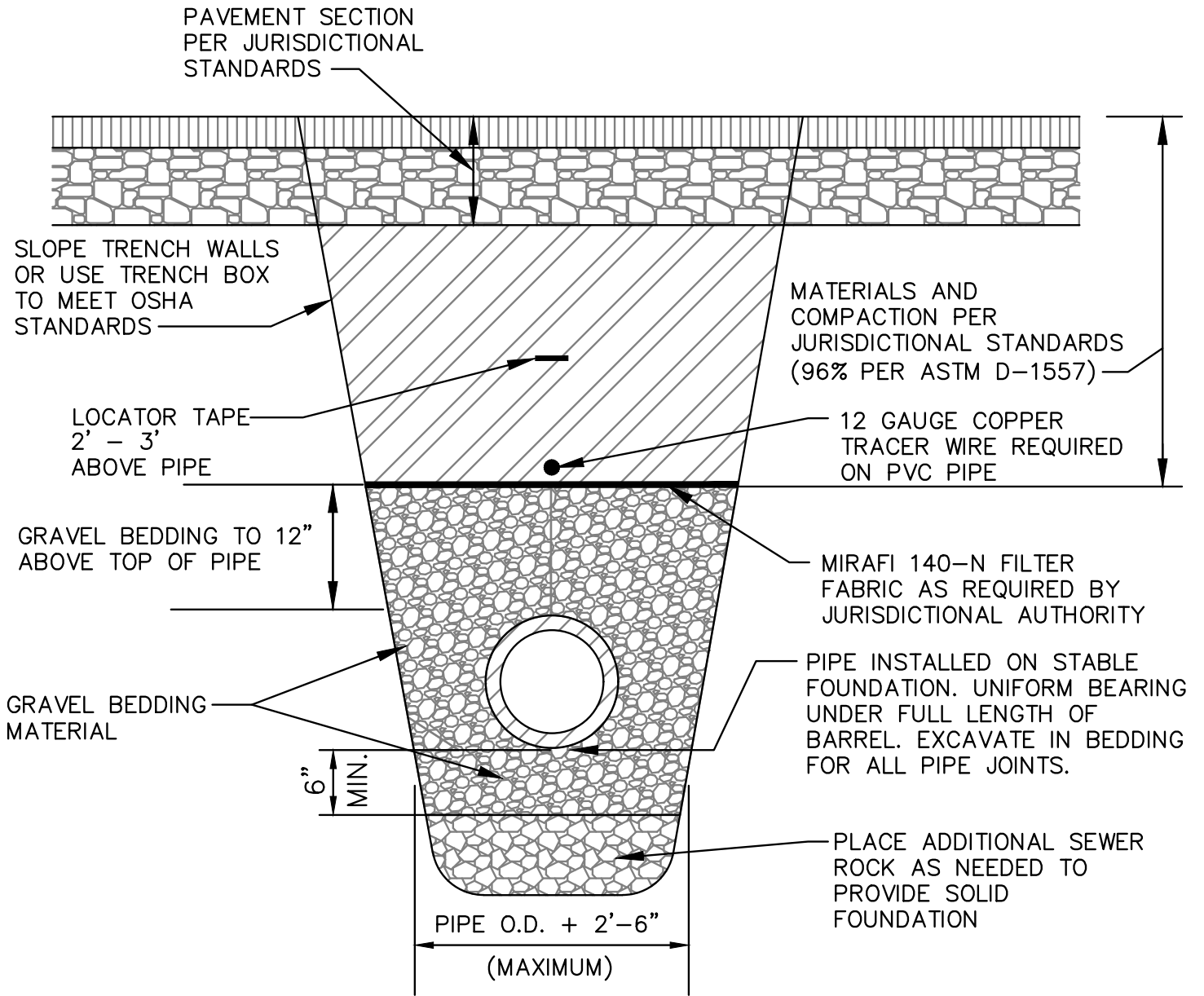

**CENTRAL DAVIS  
SEWER DISTRICT**

TYPICAL TRENCH SECTION  
IN PAVED AREAS

STANDARD DETAIL

101

Revision Date:

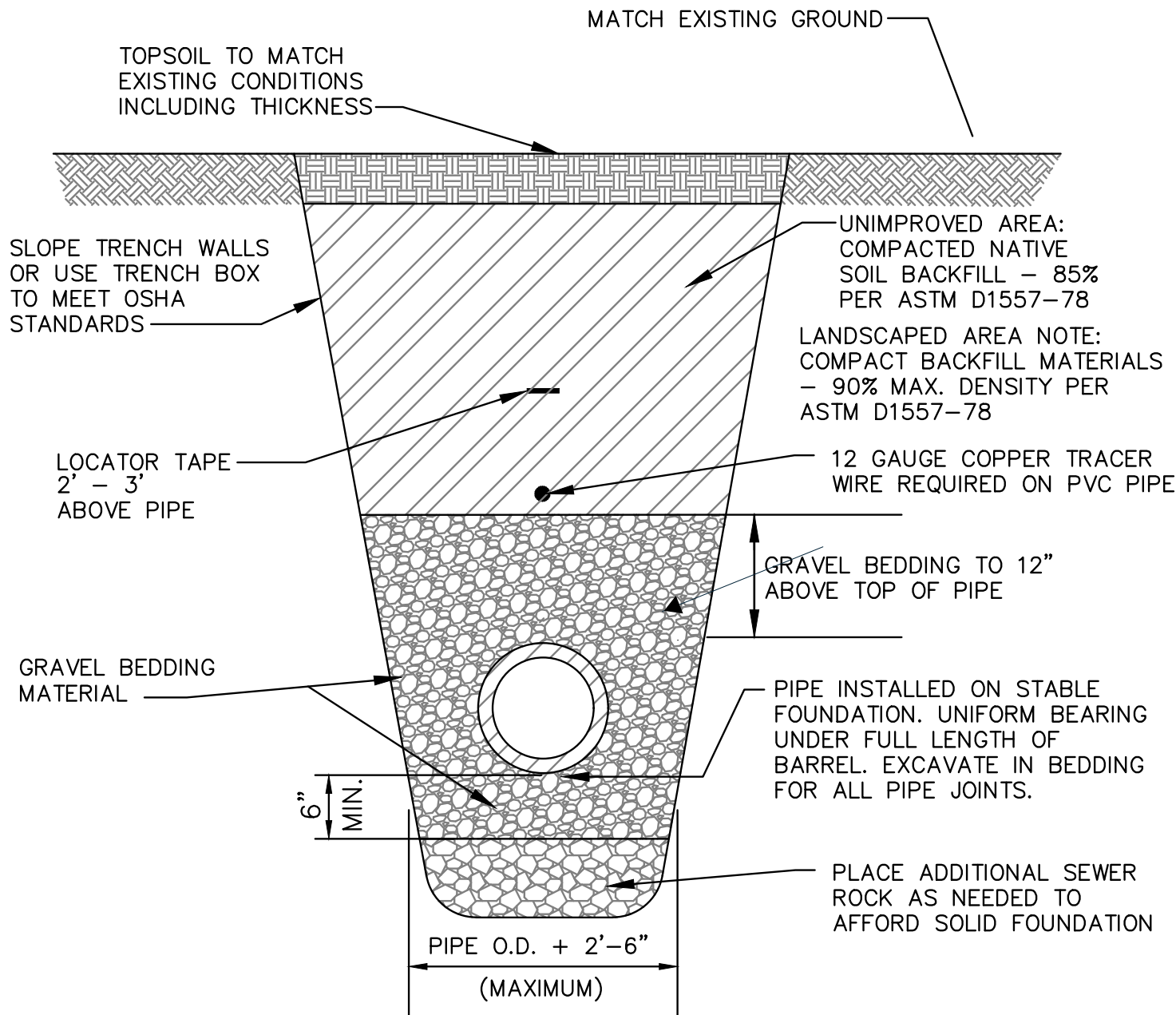

NOTES:

1. CONCRETE MATERIAL SHALL BE 1500 P.S.I. STRENGTH.
2. PLUG SHALL BE WATERTIGHT FOR ENTIRE TRENCH WIDTH.
3. PLUGS SHALL BE LOCATED AT A MAXIMUM OF 400 FOOT INTERVALS ALONG ENTIRE LENGTH OF PIPE, AS SHOWN ON THE DRAWINGS, OR AS DIRECTED BY DISTRICT INSPECTOR.

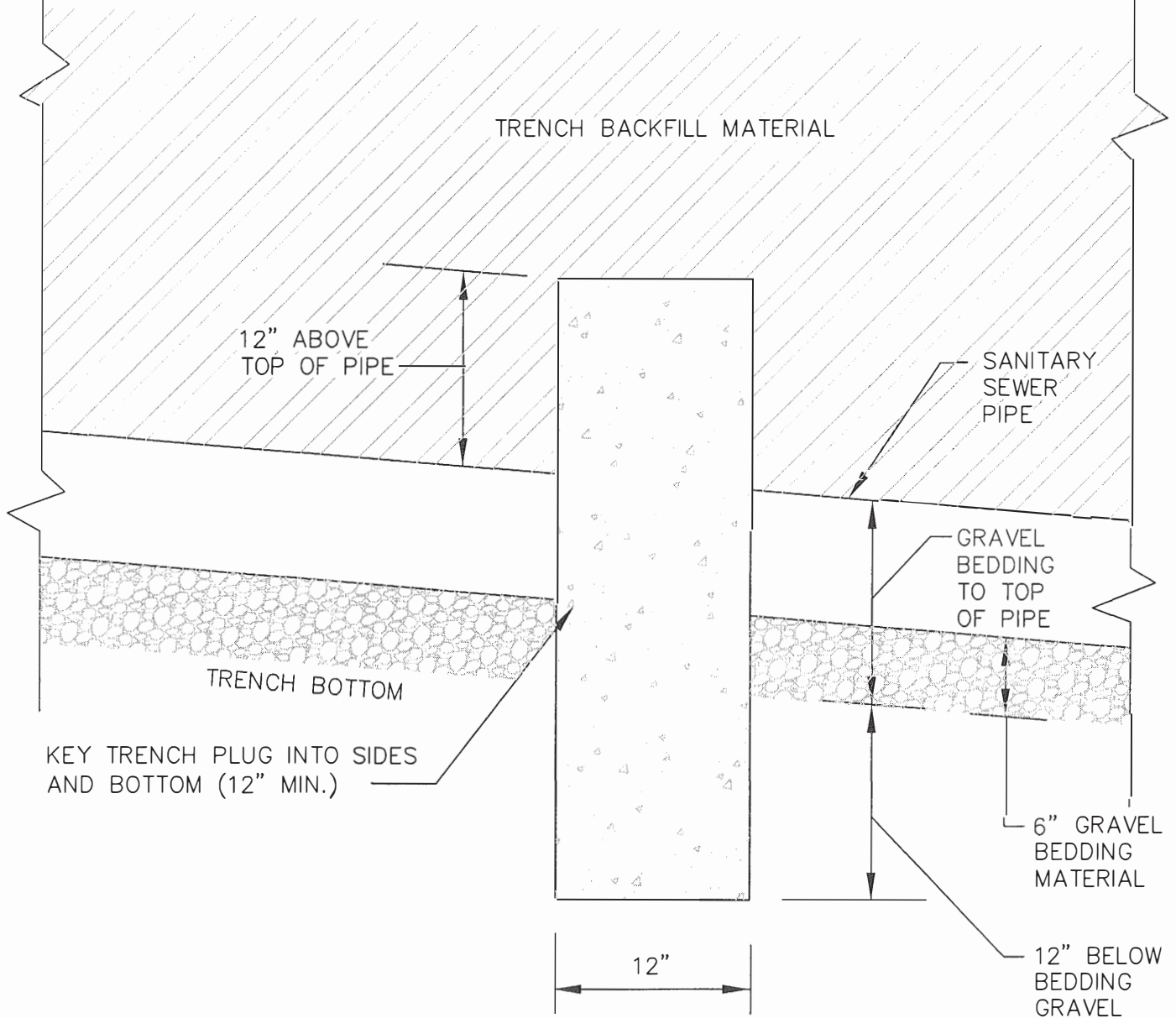

**CENTRAL DAVIS  
SEWER DISTRICT**

TYPICAL TRENCH PLUG DETAIL

STANDARD DETAIL

**103**

Revision Date:

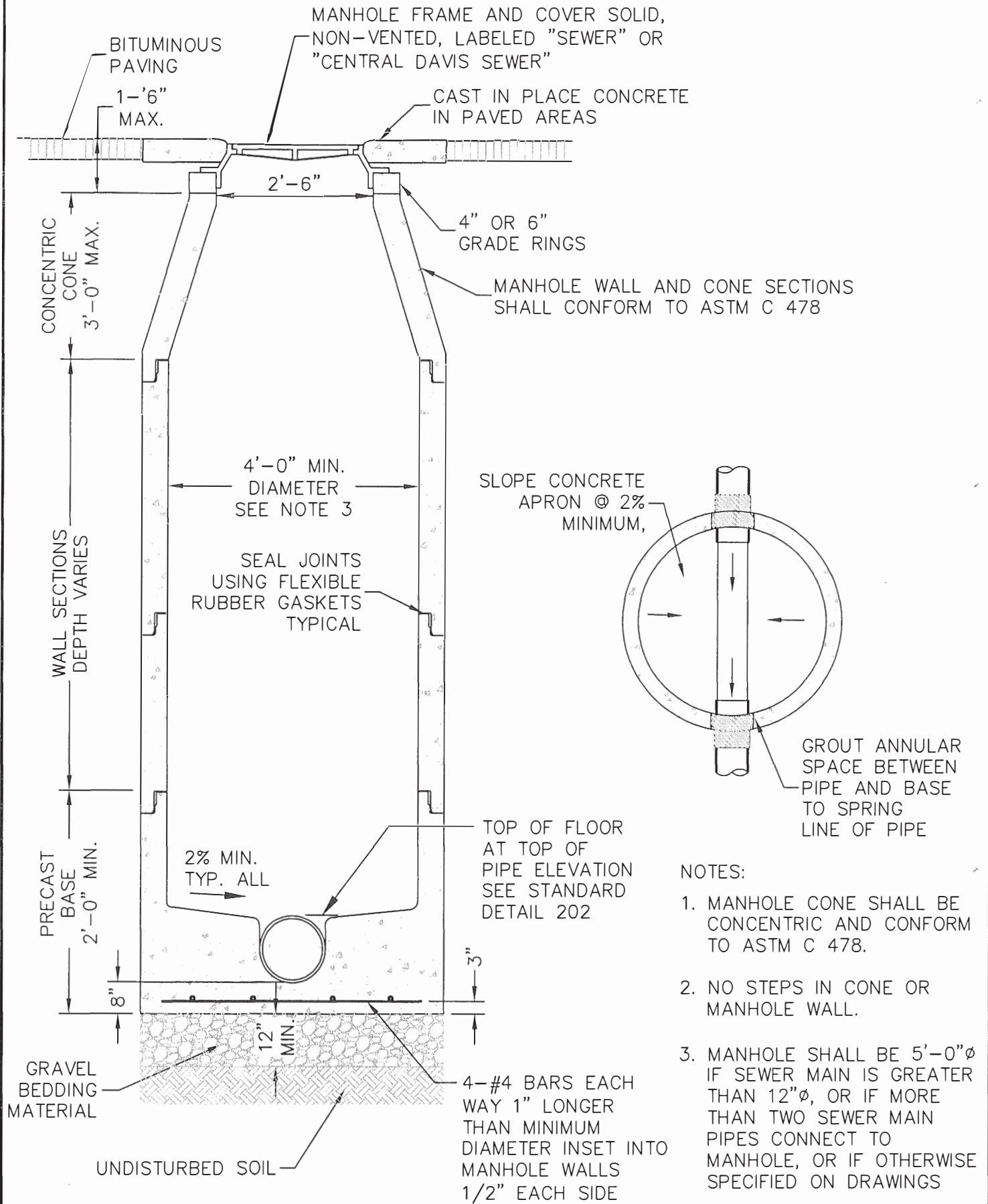

**CENTRAL DAVIS  
SEWER DISTRICT**

MANHOLE SECTION WITH NEW BASE

STANDARD DETAIL

**201**

Revision Date:

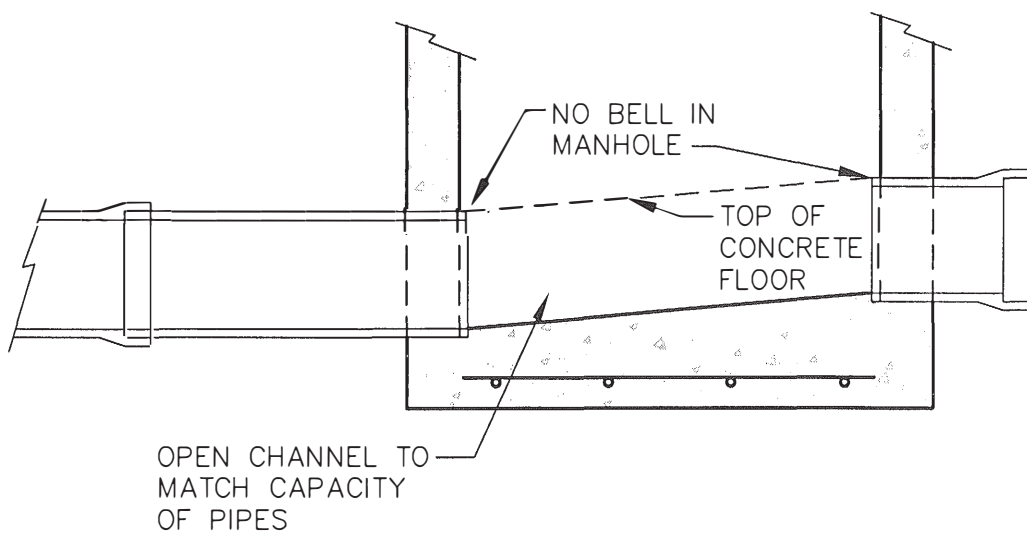
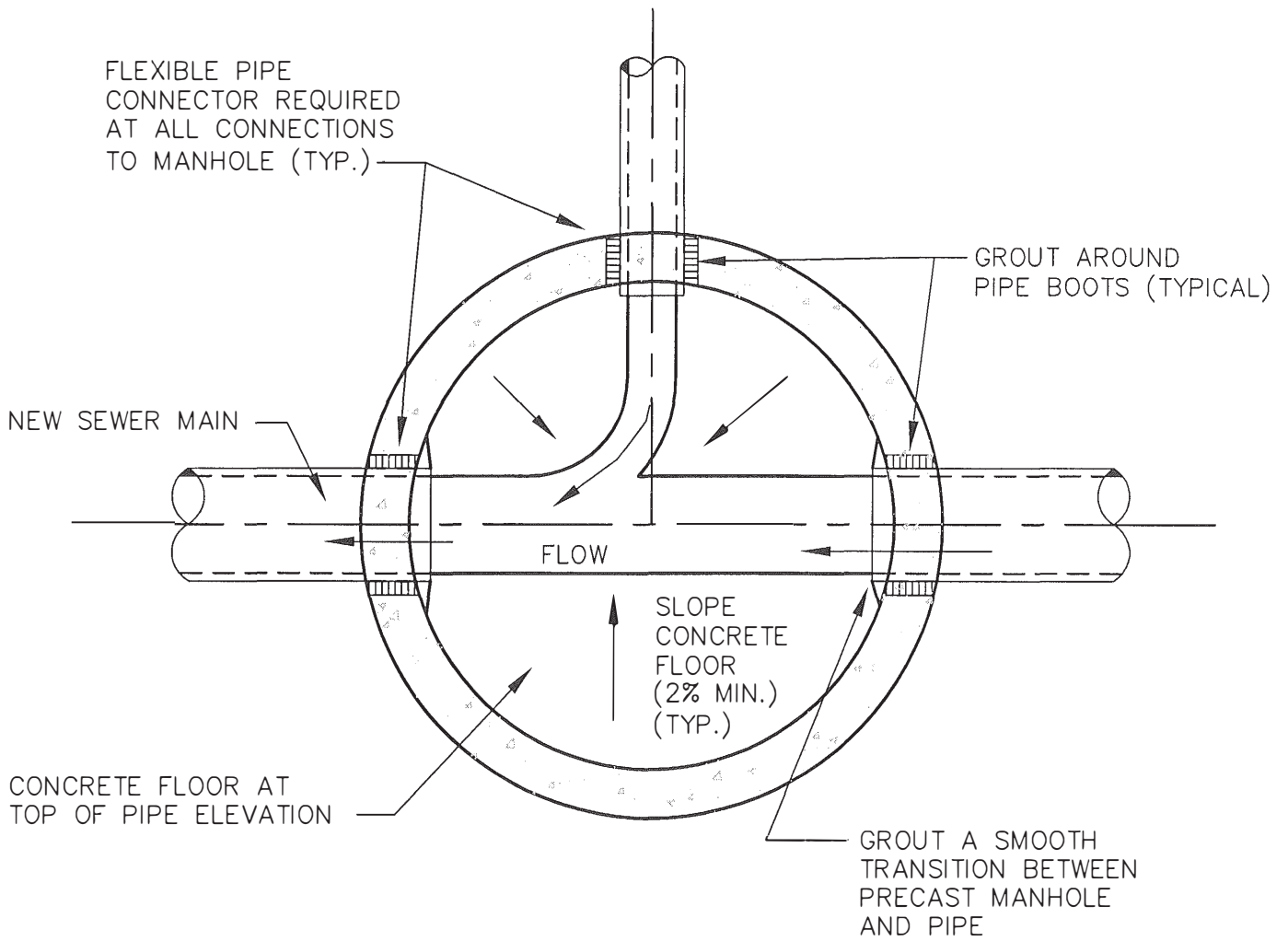

**CENTRAL DAVIS  
SEWER DISTRICT**

NEW MANHOLE PLAN

STANDARD DETAIL

**202**

Revision Date:

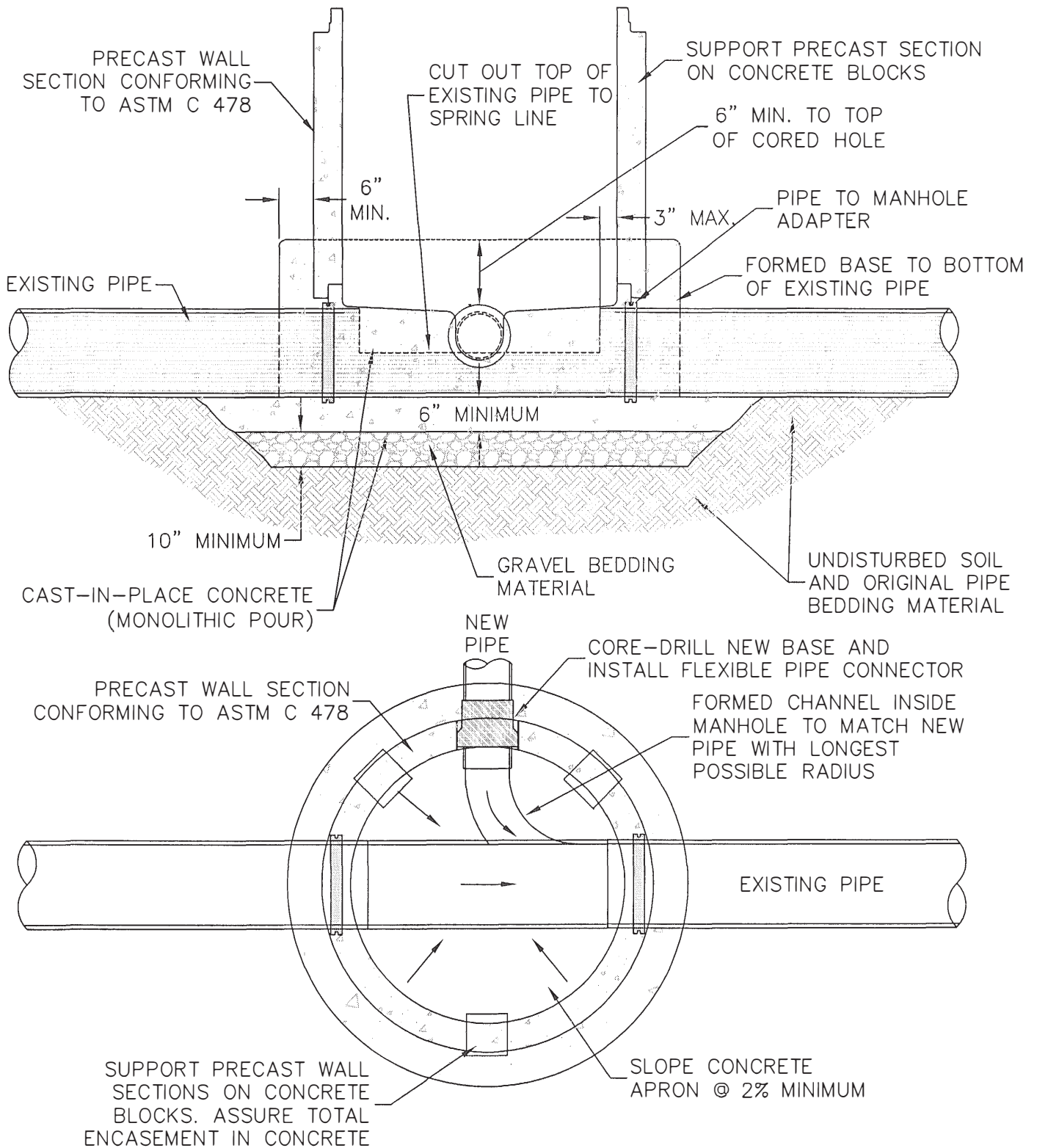

**CENTRAL DAVIS SEWER DISTRICT**

CAST-IN-PLACE MANHOLE BASE

STANDARD DETAIL

**203**

Revision Date:

NOTES:

1. PIPE AND FITTINGS FOR DROP SHALL BE ASTM 3034 SDR 35 PVC.
2. SEE STANDARD DETAIL NO. MH-01 FOR ADDITIONAL REQUIREMENTS AND SPECIFICATIONS.

MANHOLE FRAME AND COVER SOLID, NON-VENTED, LABELED "SEWER" OR "CENTRAL DAVIS SEWER"

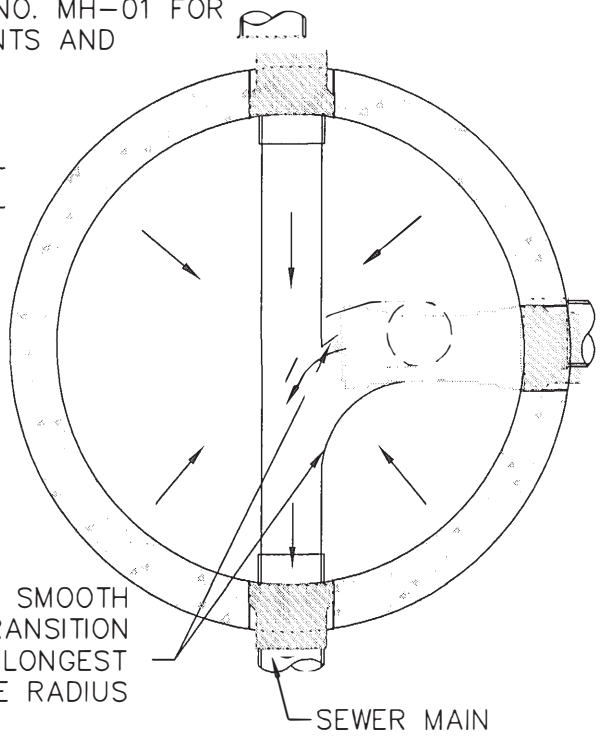
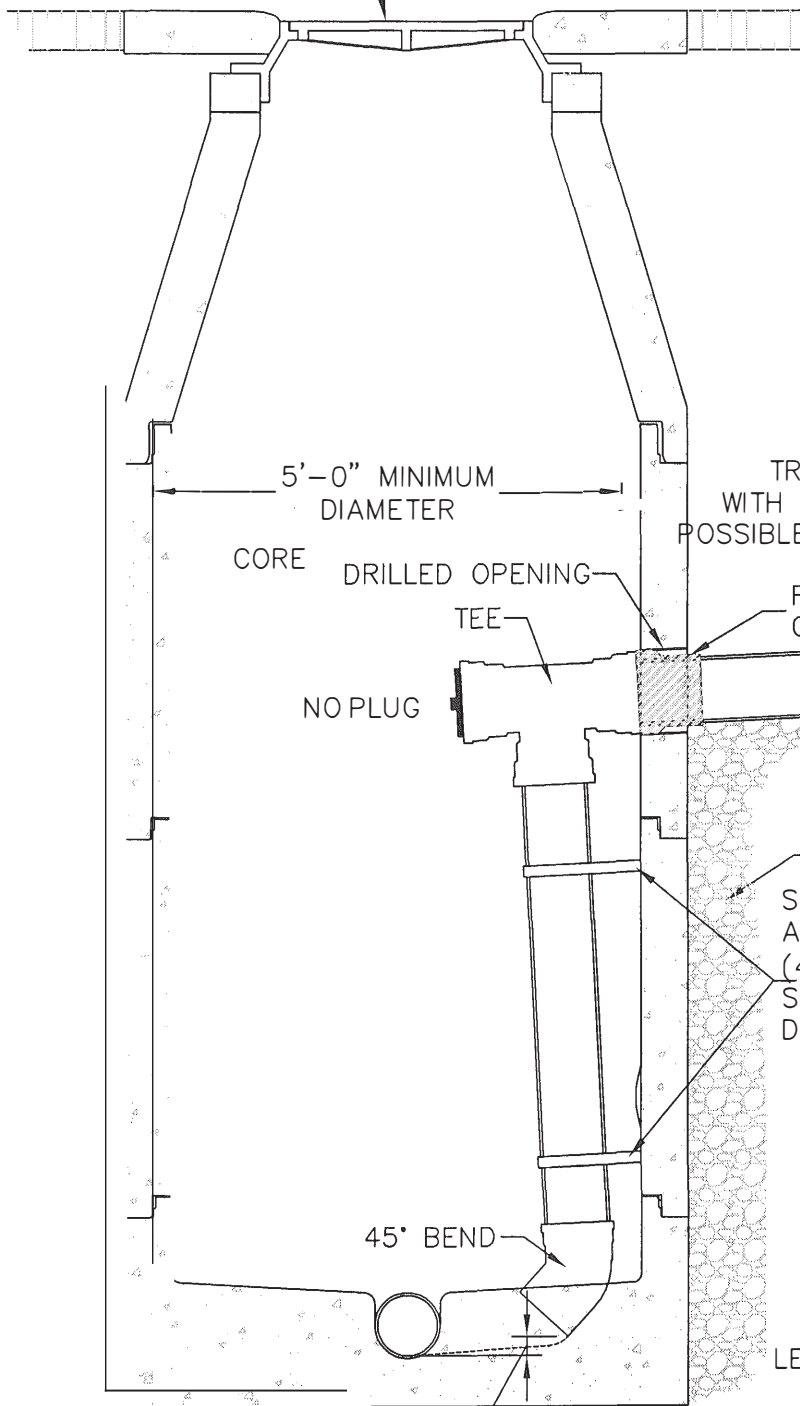

5'-0" MINIMUM DIAMETER

CORE DRILLED OPENING

TEE

NO PLUG

FLEXIBLE PIPE CONNECTOR

SEWER MAIN

BEDDING MATERIAL

STAINLESS STEEL ANCHOR STRAPS (4 FT MAX. SPACING) SEE ANCHOR STRAP DETAIL

45° BEND

3/8" STAINLESS STEEL EPOXY ANCHOR BOLTS

PRESSURE TREATED FORMED WOOD BLOCKING ENTIRE LENGTH OF DROP LEG

2"x1/8" STAINLESS STEEL STRAP

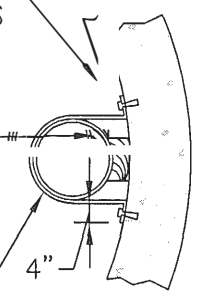

ANCHOR STRAP DETAIL

0.2' MINIMUM DROP IN FORMED FLOW CHANNEL



CENTRAL DAVIS SEWER DISTRICT

DROP MANHOLE

STANDARD DETAIL

204

Revision Date:

POWER SLEEVE  
COLLAPSED INSIDE  
GASKET BEFORE  
MECHANICAL  
EXPANSION

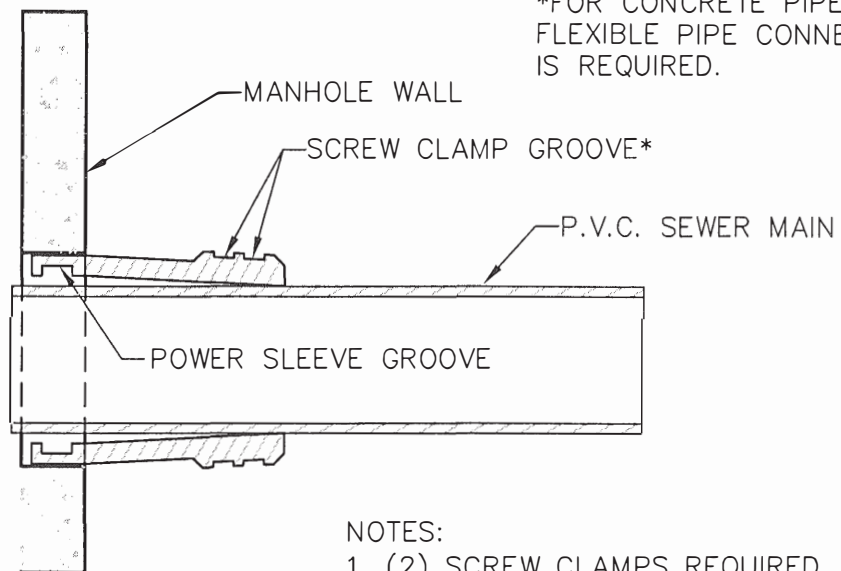

\*FOR CONCRETE PIPE, A  
FLEXIBLE PIPE CONNECTOR  
IS REQUIRED.

NOTES:

1. (2) SCREW CLAMPS REQUIRED ONLY ON PIPE LARGER THAN 14" O.D.
2. WORK AND MATERIALS SHALL CONFORM TO ASTM C923



**CENTRAL DAVIS  
SEWER DISTRICT**

CONNECTION OF P.V.C. SEWER PIPE  
TO PRE-CAST MANHOLE BASE

STANDARD DETAIL

**205**

Revision Date:



GENERAL NOTES:

1. VIDEO INSPECT ALL SEWER LINES PRIOR TO ACCEPTANCE BY THE DISTRICT.
2. MINIMUM SLOPE FOR 8"  $\phi$  RESIDENTIAL SANITARY SEWER LINES IS 0.50%.
3. NO DEADEND LINES WITH HOMES CONNECTED (SEE DETAIL BELOW).
4. NO SEWER LATERAL CONNECTIONS TO BE MADE TO A MANHOLE ON A SEWER MAIN, EXCEPT CUL-DE-SAC MANHOLES OR AS APPROVED BY THE DISTRICT.

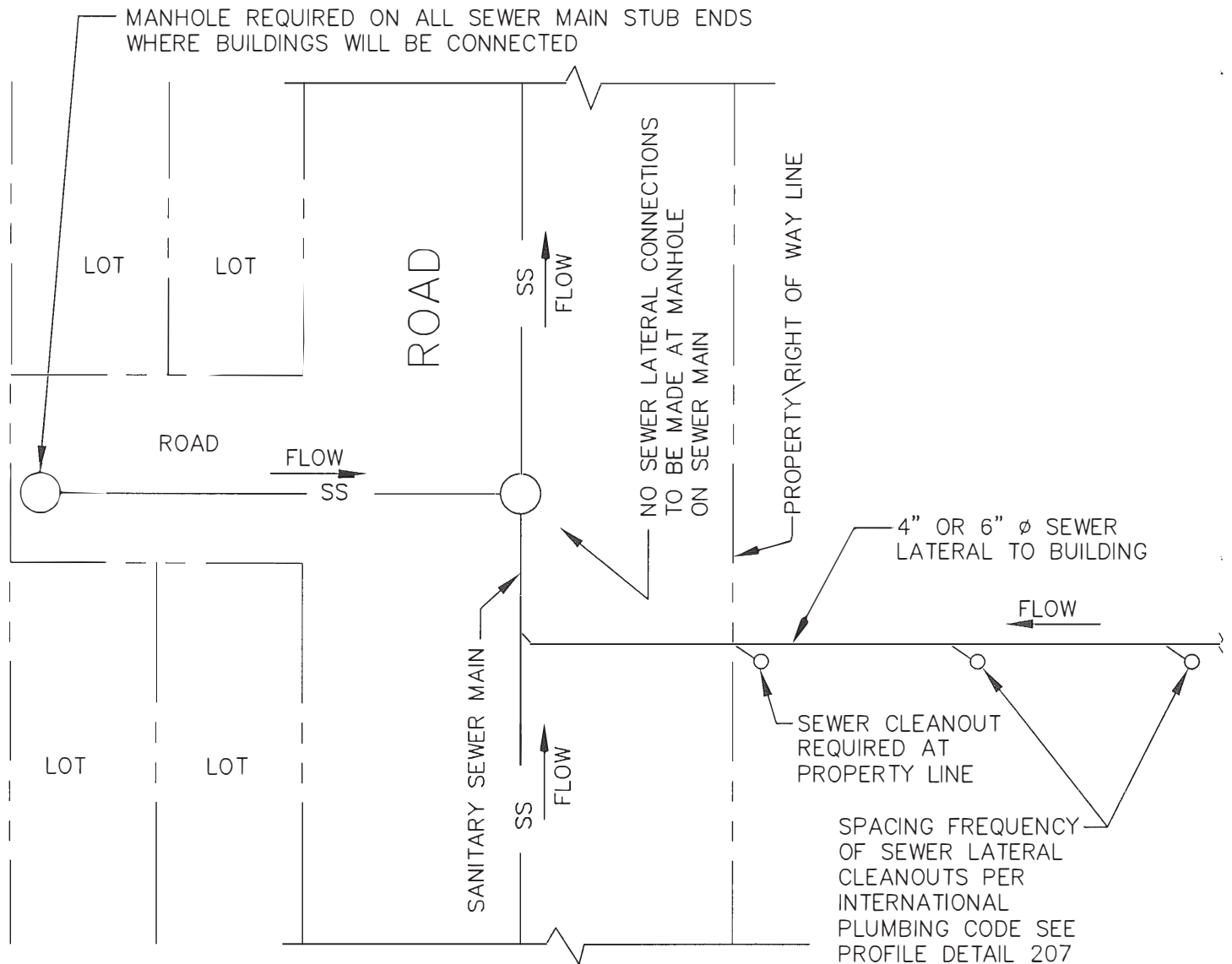

**CENTRAL DAVIS  
SEWER DISTRICT**

TYPICAL SEWER MAIN  
AND SEWER LATERAL PLAN

STANDARD DETAIL

**206**

Revision Date:

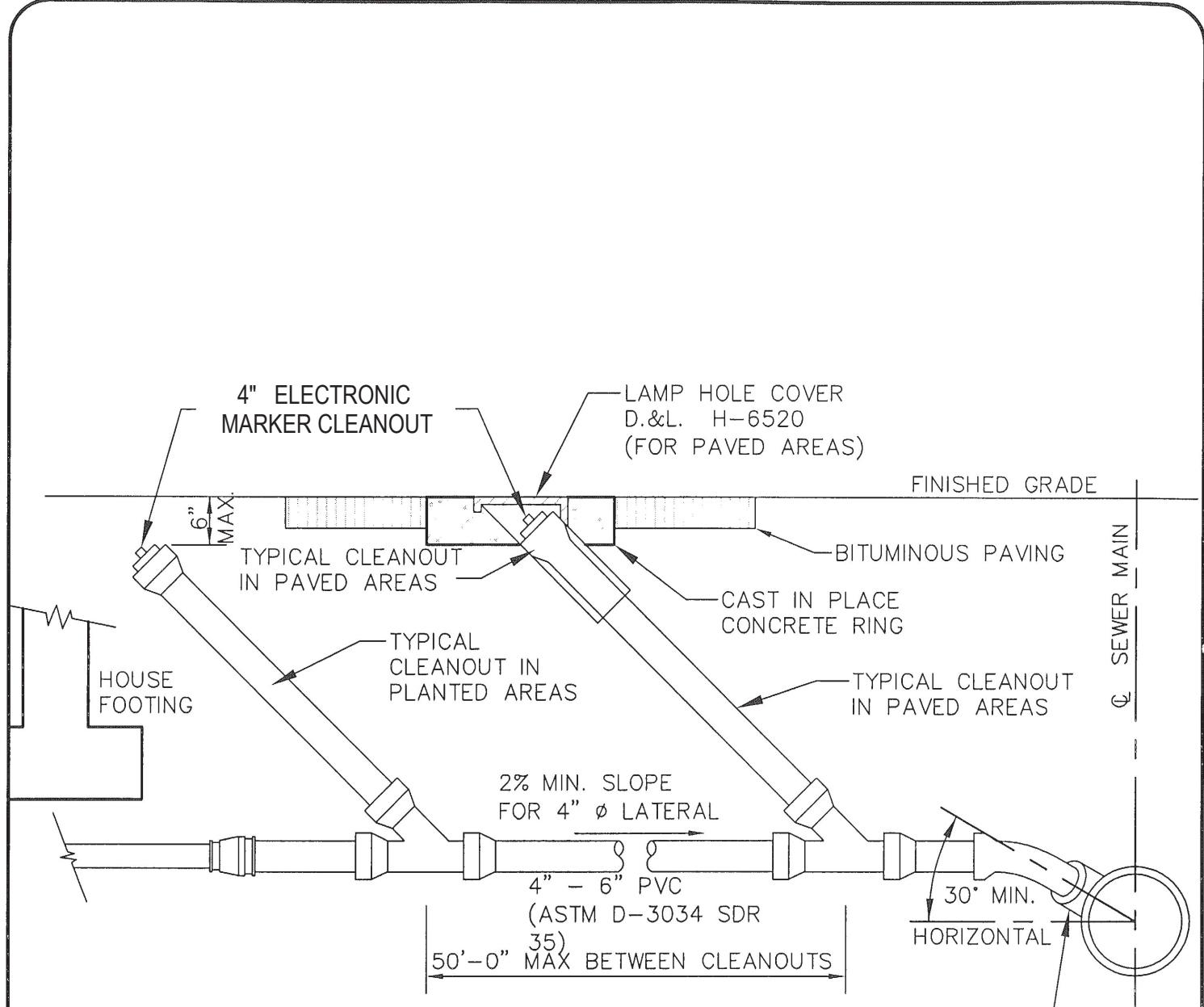

**NOTES:**

1. CLEANOUTS ARE REQUIRED AT A MAXIMUM OF 50'-0" SPACING ALONG LATERALS
2. CLEANOUT MUST BE LOCATED AT PROPERTY LINE
3. ELECTRONIC MARKER CLEANOUT CAP PROVIDED BY CDS.
4. INSTALL BACKWATER VALVE PER IPC CODE REQUIREMENTS.

INSTALL FACTORY MADE WYE FOR NEW SEWER MAINS. INSTALL SADDLE ATTACHMENT, ROMAC STYLE "CB," FOR NOSE-ON TO EXISTING SEWER MAIN AT SEWER LATERAL CONNECTION

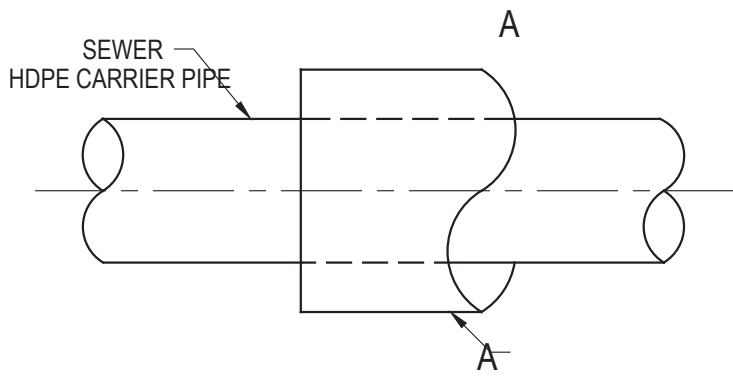

**CASING DETAIL**

see note 4

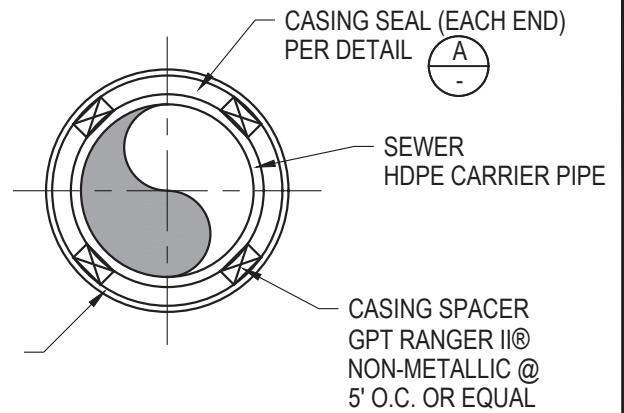

**CASING SECTION A-A**

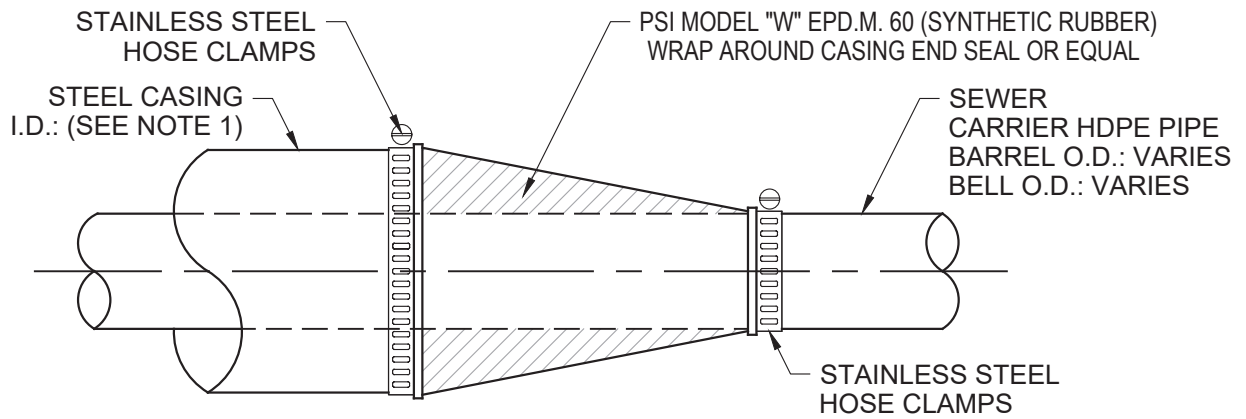

**CASING END SEAL DETAIL A**

See notes on next page

NOTES:

1. LOCATIONS REQUIRING STEEL CASING

- a. STEEL CASINGS SHALL BE REQUIRED ON ALL SEWER LINES THAT CROSS STREETS WITH A FUNCTIONAL CLASSIFICATION OF MINOR ARTERIAL OR HIGHER.
- b. STEEL CASINGS SHALL BE REQUIRED ON ALL SEWER LINES THAT CROSS RAILROADS OR RAILROAD TRAILS. THESE REQUIREMENTS ARE A MINIMUM. ALL RAILROAD CROSSINGS MUST BE PERMITTED BY THE RAILROAD AND MEET THE REQUIREMENTS OF THAT PERMIT IF THEY ARE MORE STRINGENT.
- c. LOCATIONS THAT WILL BE EXTREMELY DIFFICULT OR COSTLY TO EXCAVATE OR MAINTAIN DUE TO DEPTH, TRAFFIC, BUILDINGS, OBSTACLES, LOCATIONS THAT MAY CAUSE DAMAGE FROM LEAKAGE OR INFILTRATION, ETC. MAY BE REQUIRED TO INSTALL A STEEL CASING. THESE ADDITIONAL LOCATIONS WILL BE REVIEWED AND REQUIRED BY THE DISTRICT ON A CASE-BY-CASE BASIS.
- d. LOCATIONS THAT REQUIRE BORING RATHER THAN AN OPEN TRENCH. DIRECTIONAL DRILLING WITHOUT A CASING IS NOT ALLOWED.

\*FOR ALL STEEL CASING LOCATIONS, THE CASING MUST BE INSTALLED MANHOLE TO MANHOLE, UNLESS AUTHORIZED BY THE DISTRICT MANAGER

- 2. AT A MINIMUM STEEL CASINGS ARE TO RUN THE ENTIRE WIDTH OF THE STREET OR RAILROAD RIGHT-OF-WAY NOT JUST WHERE THE ASPHALT OR TRACKS ARE PLACED.
- 3. STEEL CASING SIZING REQUIREMENTS: STEEL CASING INSIDE DIAMETER (I.D.) = OUTSIDE DIAMETER (O.D.) OF CARRIER PIPE BELL + 4" MINIMUM TO ALLOW FOR A 2" MINIMUM CLEARANCE ALL AROUND.
- 4. STEEL CASING MINIMUM WALL THICKNESS SHALL BE BASED ON THE FOLLOWING TABLE.

STEEL CASING MINIMUM THICKNESS	DIAMETER OF CASING PIPE
1/4" (0.2500")	12" OR LESS
5/16" (0.3125")	OVER 12"-18"
3/8" (0.3750")	OVER 18"-22"
7/16" (0.4375)	OVER 22"-28"
1/2" (0.5000")	OVER 28"-34"
9/16" (0.5625)	OVER 34"-42"
5/8" (0.6250")	OVER 42"-48"

- 5. MODIFICATIONS TO THESE REQUIREMENTS MUST BE APPROVED BY THE DISTRICT PRIOR TO



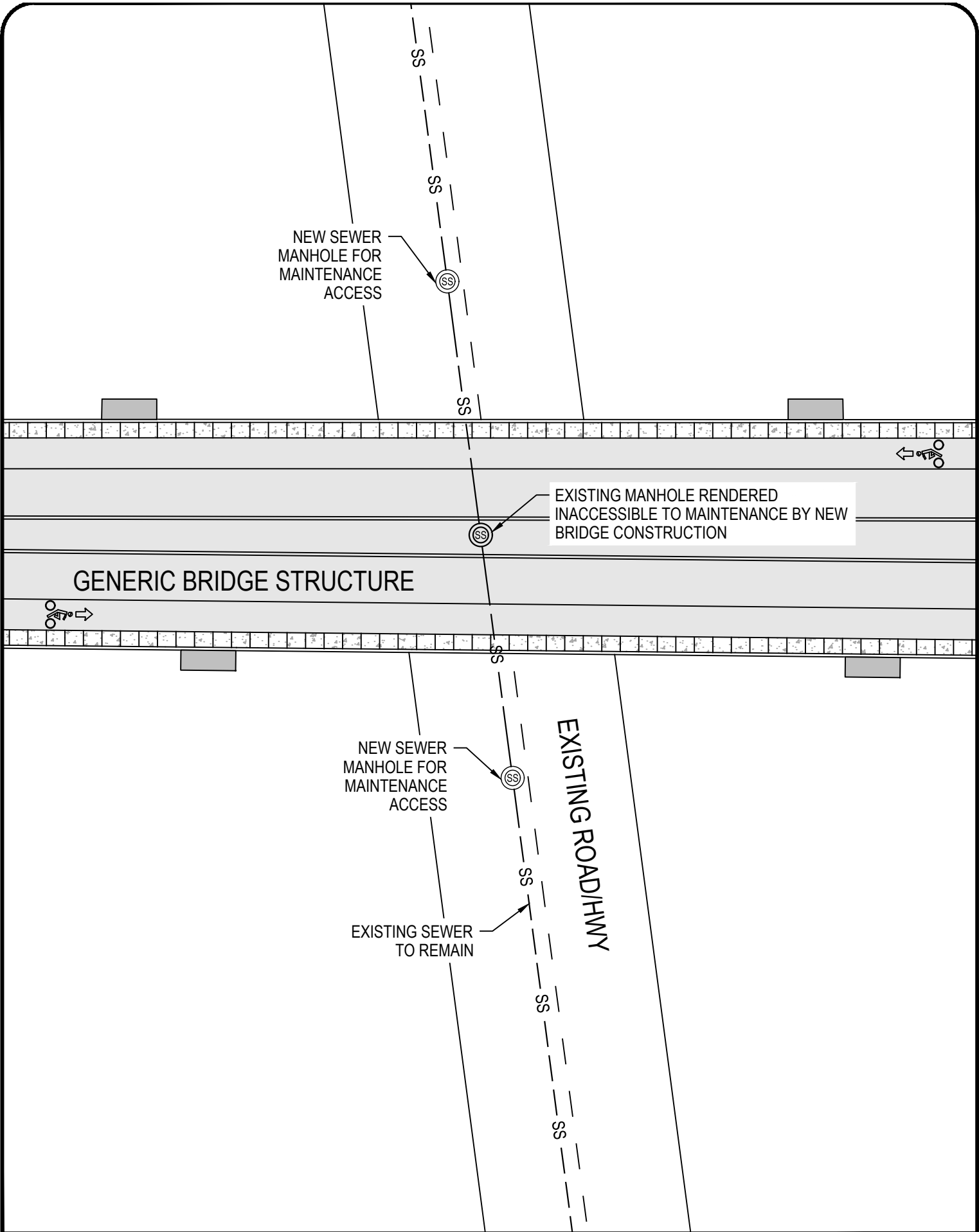

**CENTRAL DAVIS  
SEWER DISTRICT**

INACCESSIBLE MANHOLE DETAIL  
NOT TO SCALE

STANDARD DETAIL

**209**

Revision Date:

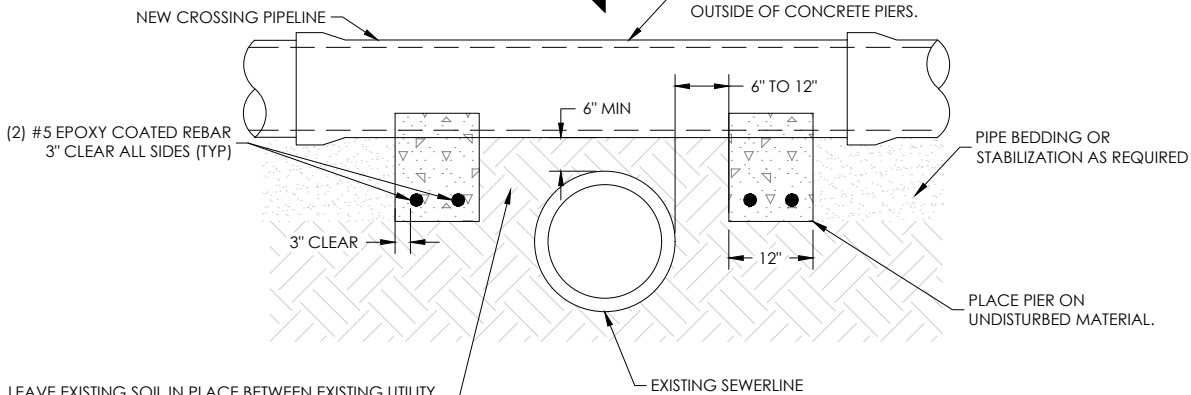
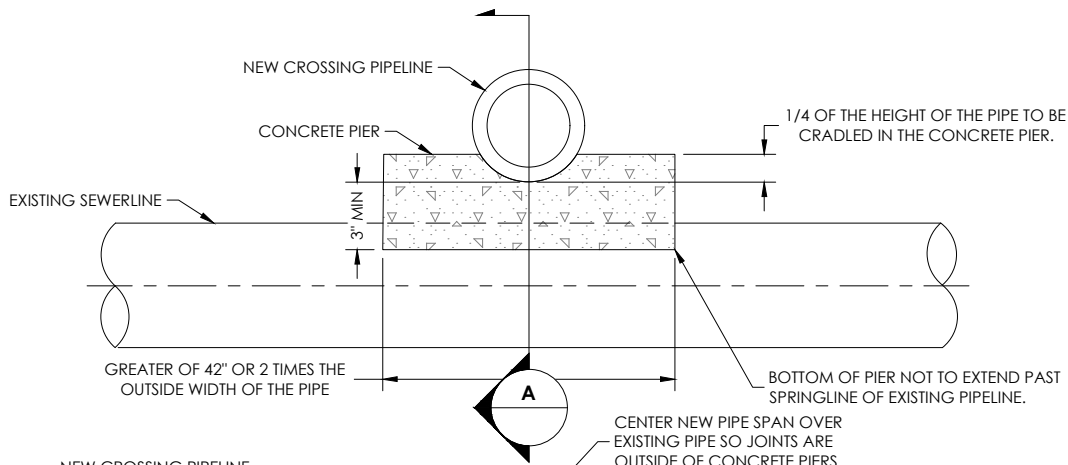

LEAVE EXISTING SOIL IN PLACE BETWEEN EXISTING UTILITY AND NEW UTILITY. FILL VOIDS FROM EXCAVATION WITH UNCOMPACTED SAND PER APWA 31 (613 TO ALLOW FURTHER COMPRESSION OF SAND OVER TIME)

**SECTION A**

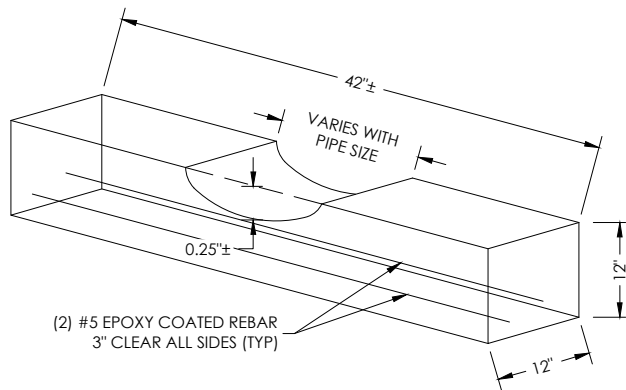

**OBLIQUE**

**NOTES:**

1. THE PURPOSE FOR PROVIDING PIERS IS TO PROTECT THE UNDERLYING SEWERLINE FROM CURRENT AND FUTURE LOADS IMPOSED BY BACKFILLING OPERATION.

2. CONCRETE: CLASS 4000, APWA 03 30 04.

3. USE CAUTION WHEN CROSSING OVER BURIED PIPELINE OR CONDUIT. DO NOT USE MACHINERY OR VIBRATORY EQUIPMENT FOR EXCAVATION AND COMPACTION WITHIN 2-FEET OF EXISTING PIPELINE.

4. UTILITY CROSSINGS WITH LESS THAN 18" OF SPACING ARE PROHIBITED UNLESS APPROVED BY CENTRAL DAVIS SEWER DISTRICT.

5. PIERS MAY ONLY BE USED AS APPROVED BY CENTRAL DAVIS SEWER DISTRICT.

6. CONTRACTOR WILL BE HELD RESPONSIBLE FOR REPAIRS IF DAMAGE IS CAUSED TO PIPELINE.



**CENTRAL DAVIS SEWER DISTRICT**

**CONCRETE PIER SUPPORTS FOR CROSSING SANITARY SEWER LINES**

STANDARD DETAILS:

**210**

REVISION DATE:

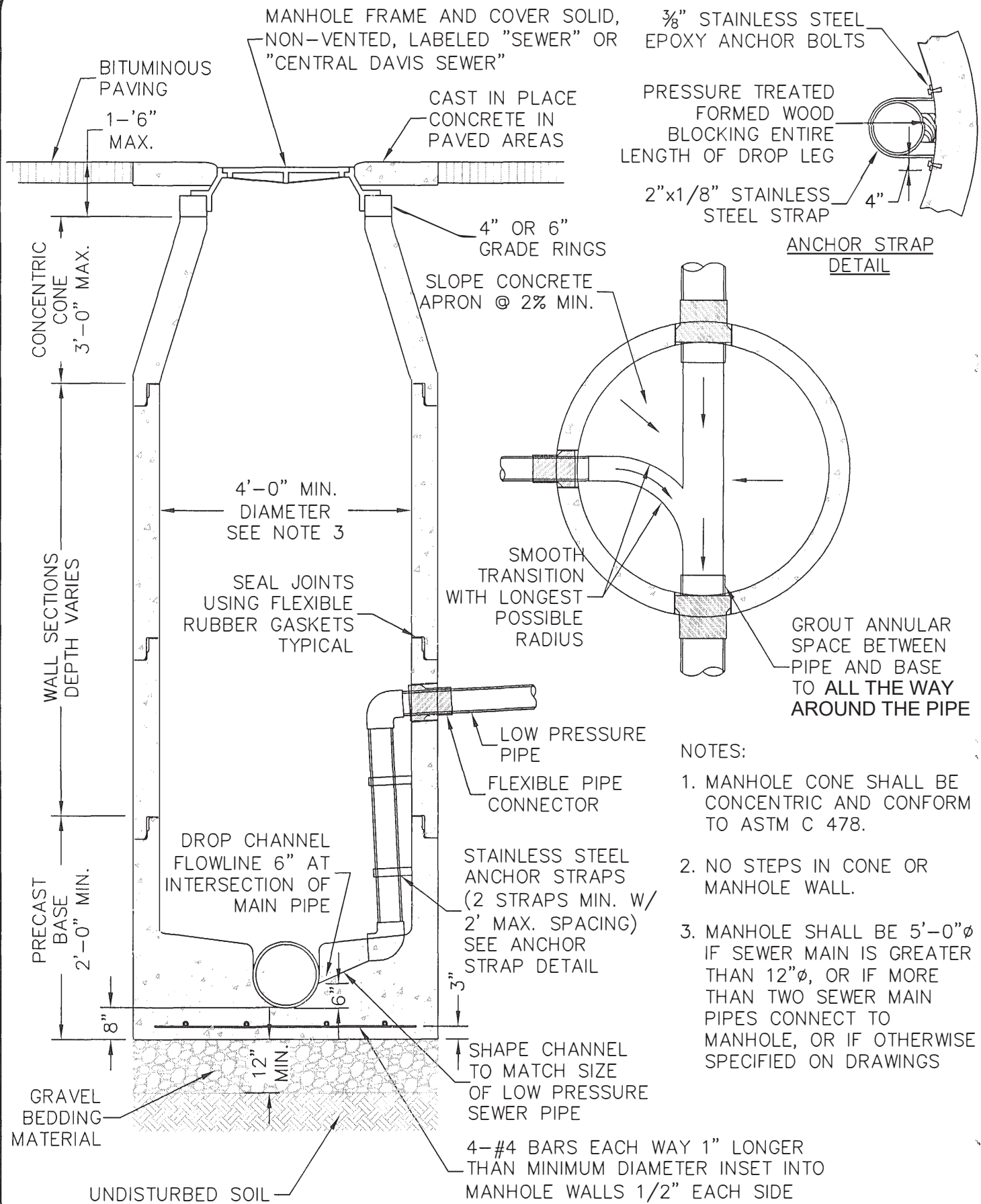

NOTES:

1. MANHOLE CONE SHALL BE CONCENTRIC AND CONFORM TO ASTM C 478.
2. NO STEPS IN CONE OR MANHOLE WALL.
3. MANHOLE SHALL BE 5'-0"  $\phi$  IF SEWER MAIN IS GREATER THAN 12"  $\phi$ , OR IF MORE THAN TWO SEWER MAIN PIPES CONNECT TO MANHOLE, OR IF OTHERWISE SPECIFIED ON DRAWINGS



**CENTRAL DAVIS  
SEWER DISTRICT**

LOW PRESSURE SEWER MAIN DROP  
CONNECTION IN EXISTING MANHOLE  
RIGHT ANGLE

STANDARD DETAIL

**301**

Revision Date:

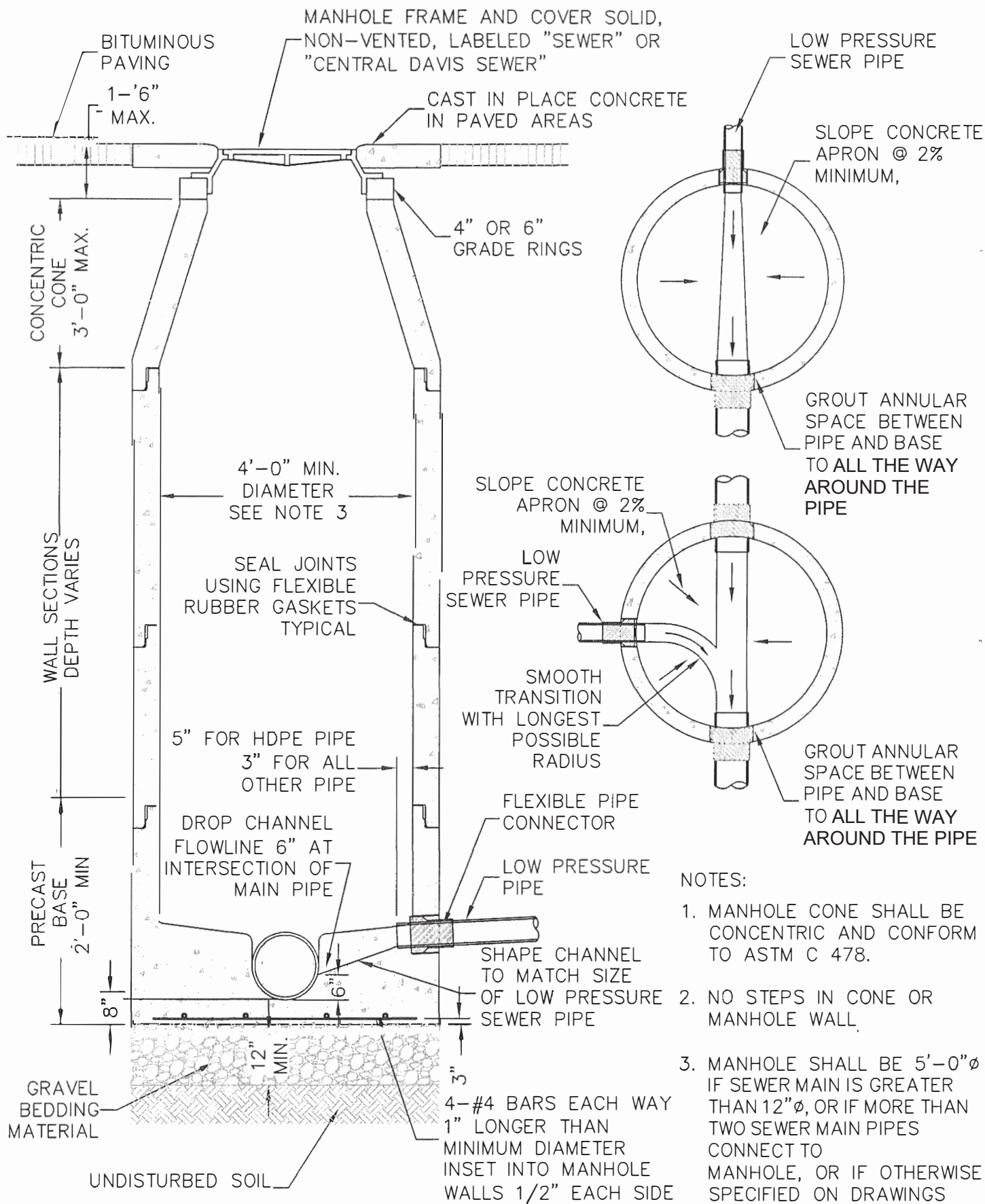

- NOTES:
1. MANHOLE CONE SHALL BE CONCENTRIC AND CONFORM TO ASTM C 478.
  2. NO STEPS IN CONE OR MANHOLE WALL.
  3. MANHOLE SHALL BE 5'-0"  $\phi$  IF SEWER MAIN IS GREATER THAN 12"  $\phi$ , OR IF MORE THAN TWO SEWER MAIN PIPES CONNECT TO MANHOLE, OR IF OTHERWISE SPECIFIED ON DRAWINGS



**CENTRAL DAVIS  
SEWER DISTRICT**

LOW PRESSURE SEWER MAIN  
TIE-IN TO EXISTING MANHOLE

STANDARD DETAIL  
**302**  
Revision Date:



MANHOLE FRAME AND COVER SOLID,  
NON-VENTED, LABELED "SEWER" OR  
"CENTRAL DAVIS SEWER"

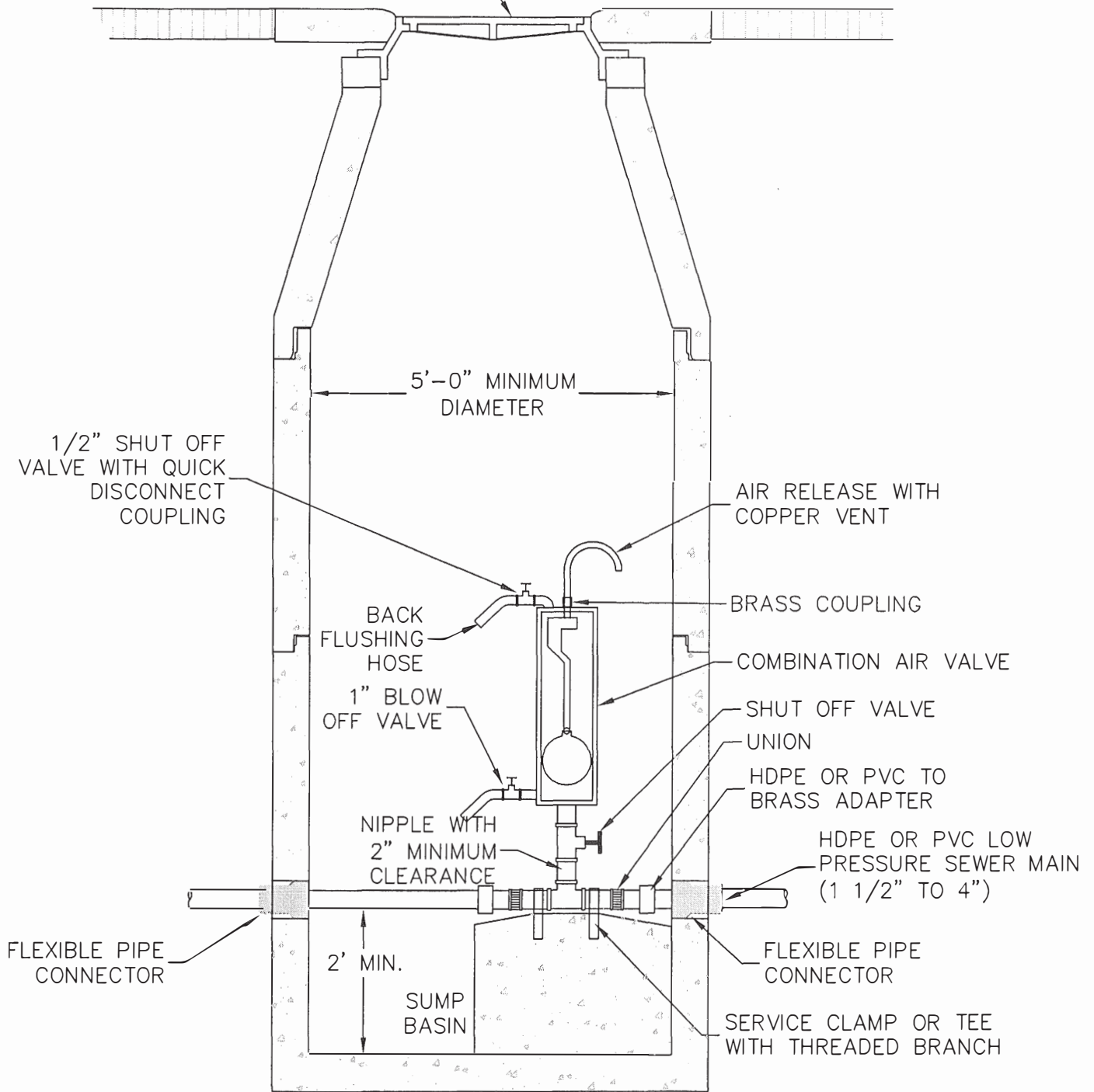

PLACE AT HIGH POINT IN SYSTEM  
AS DIRECTED BY DISTRICT

NOTE: ALL PIPE AND FITTINGS SHALL BE BRASS  
SEE DETAIL 201 FOR TYPICAL MANHOLE DETAIL



**CENTRAL DAVIS  
SEWER DISTRICT**

LOW PRESSURE SEWER  
COMBINATION AIR VALVE  
ON MAIN LINE

STANDARD DETAIL

**303**

Revision Date:

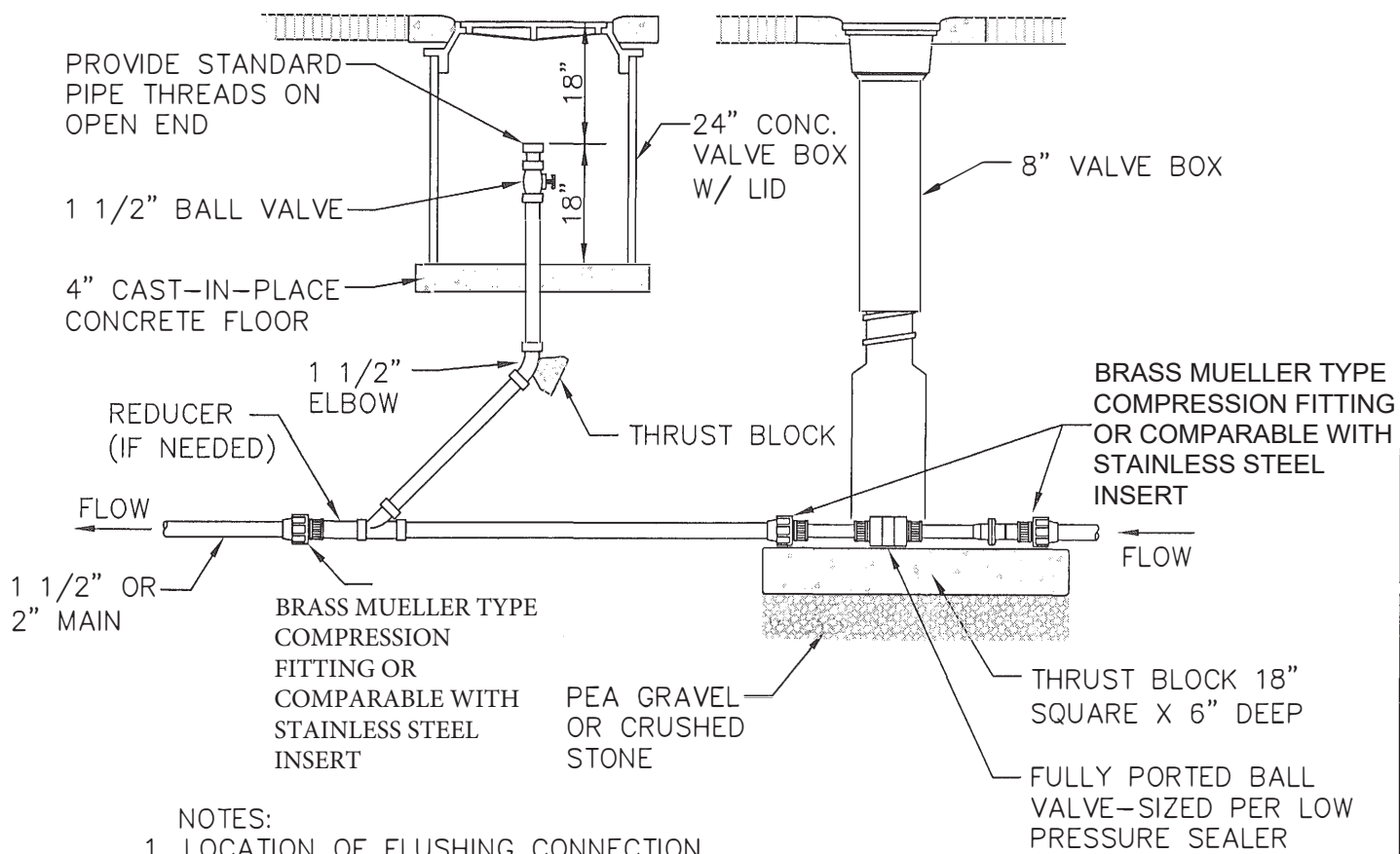
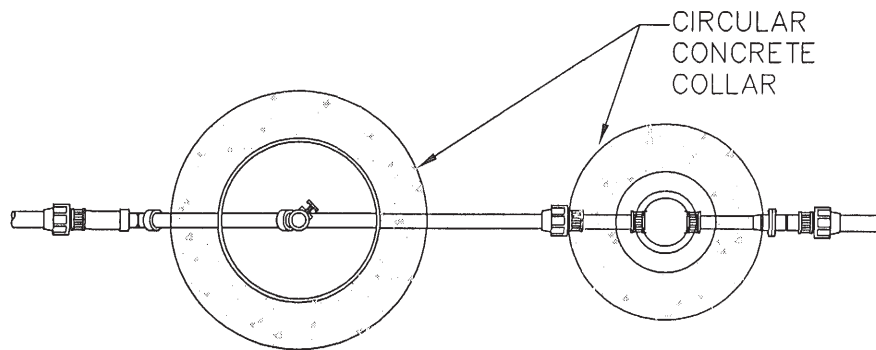

- NOTES:
1. LOCATION OF FLUSHING CONNECTION SHALL BE AT 200 FEET ON CENTER.
  2. ALL MATERIALS SHALL BE CTS POLY PIPE WITH 200 PSI OPERATION PRESSURE.
  3. MAIN SEWER LINES AND LATERALS TO THE CURB BOX MUST WRAPPED IN 3 INCH DETECTABLE SEWER TAPE.



**CENTRAL DAVIS SEWER DISTRICT**

LOW PRESSURE SEWER  
TYPICAL FLUSHING CONNECTION ON MAIN LINE

STANDARD DETAIL  
**304**  
Revision Date:

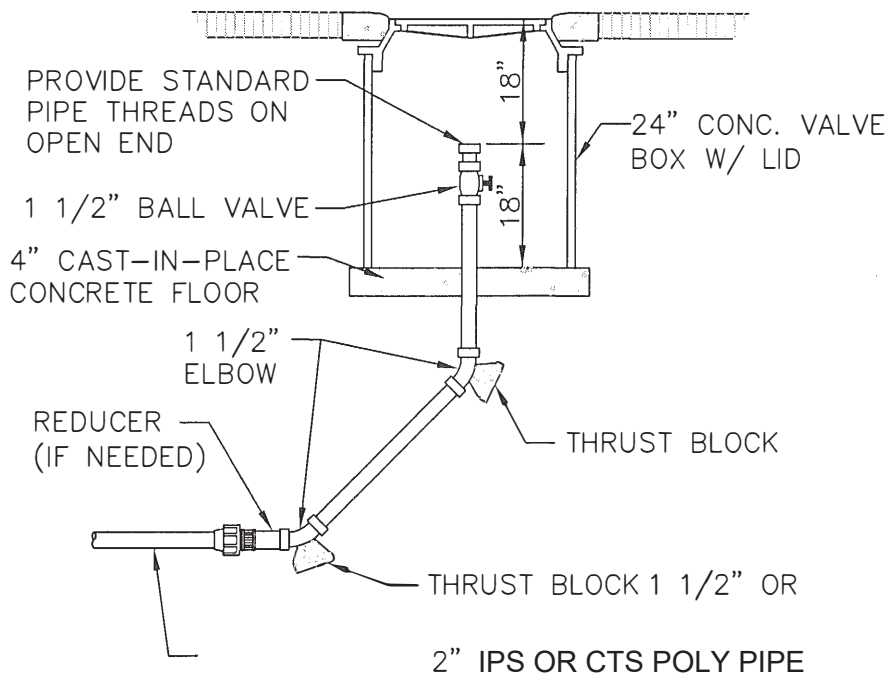
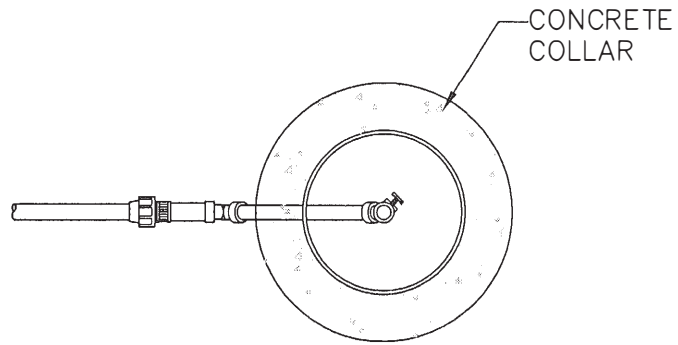

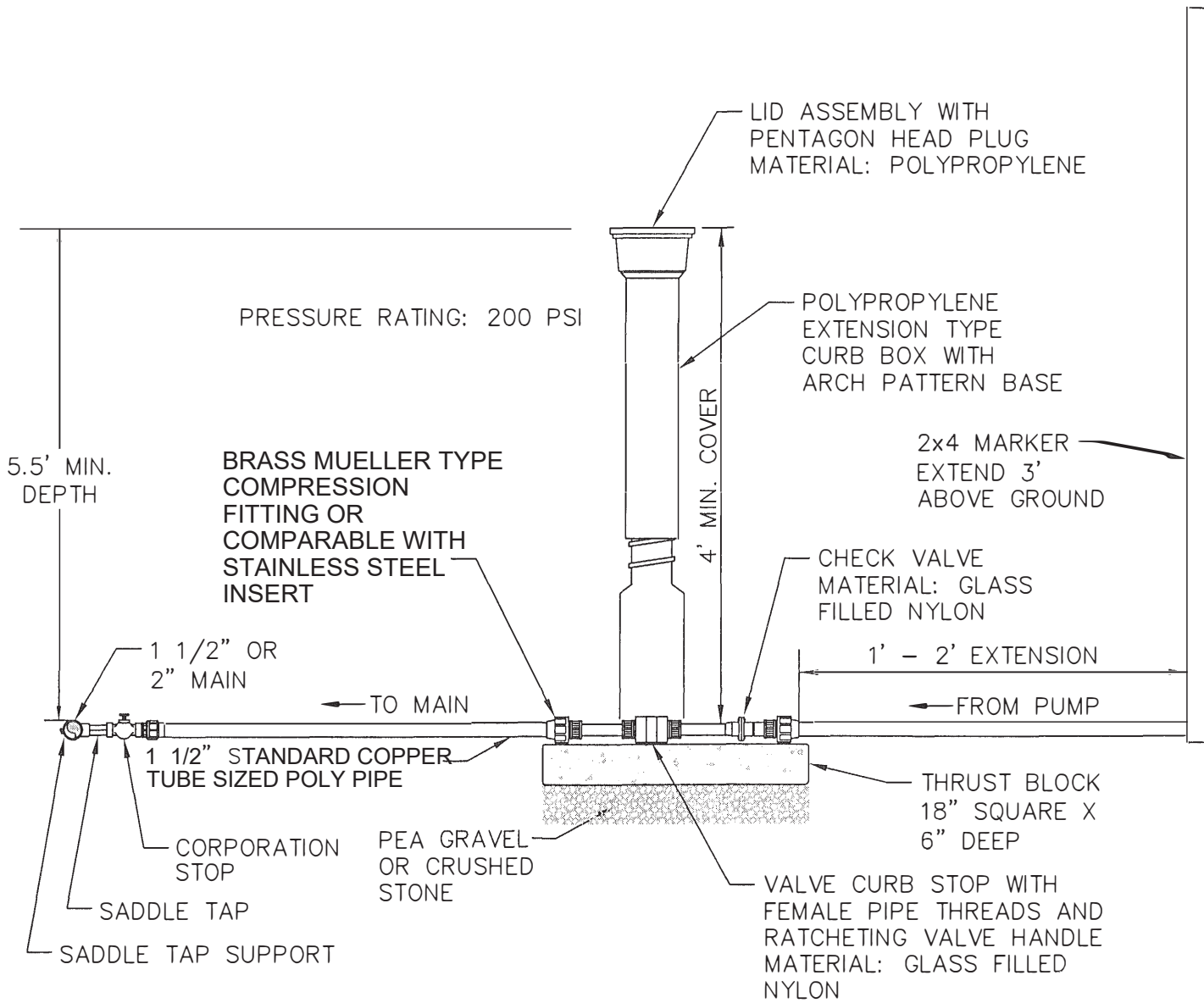

**CENTRAL DAVIS SEWER DISTRICT**

LOW PRESSURE SEWER PRIVATE LATERAL ASSEMBLY

STANDARD DETAIL

**306**

Revision Date:

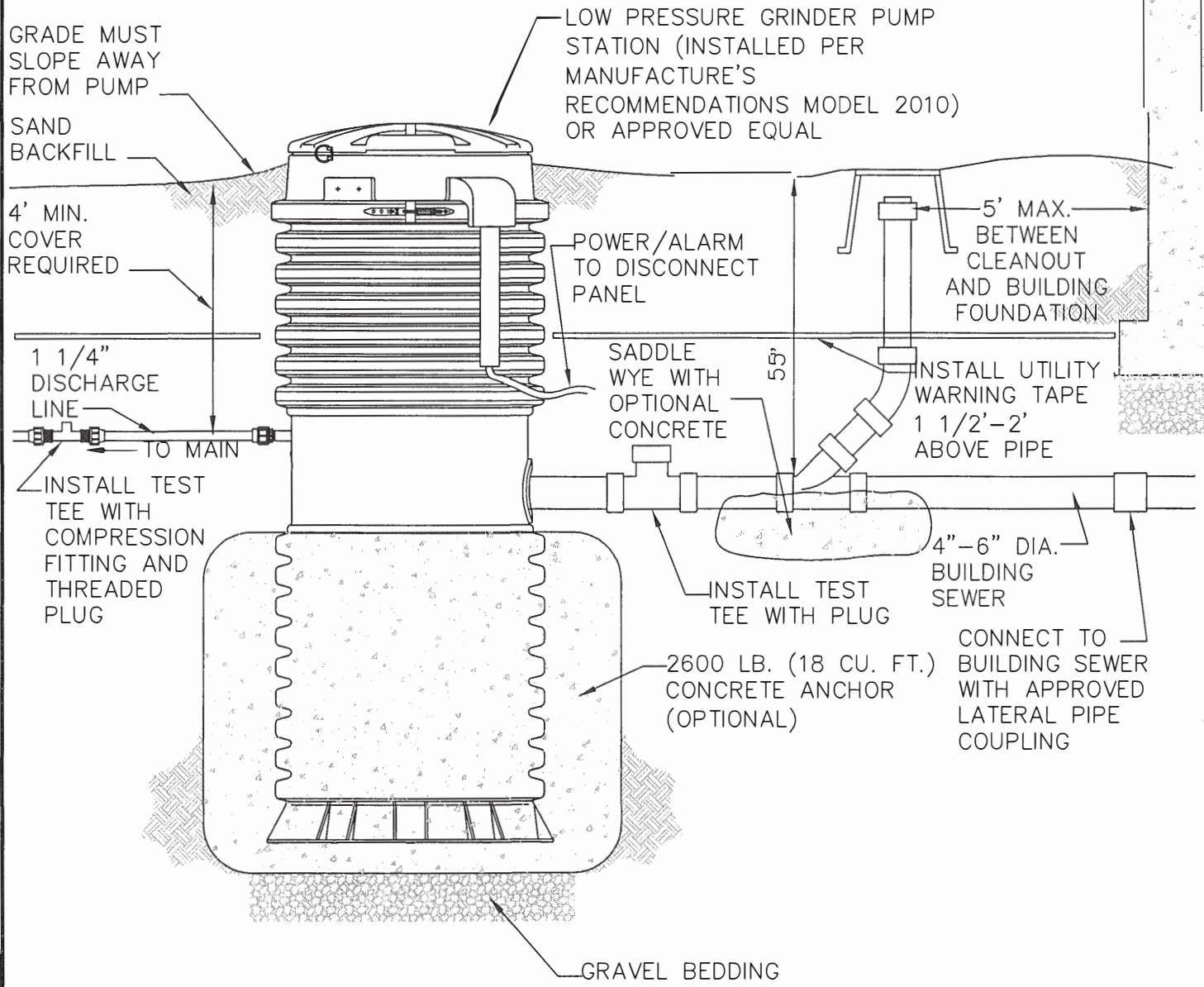

**CENTRAL DAVIS SEWER DISTRICT**

LOW PRESSURE SEWER PUMP ASSEMBLY

STANDARD DETAIL

**307**

Revision Date:

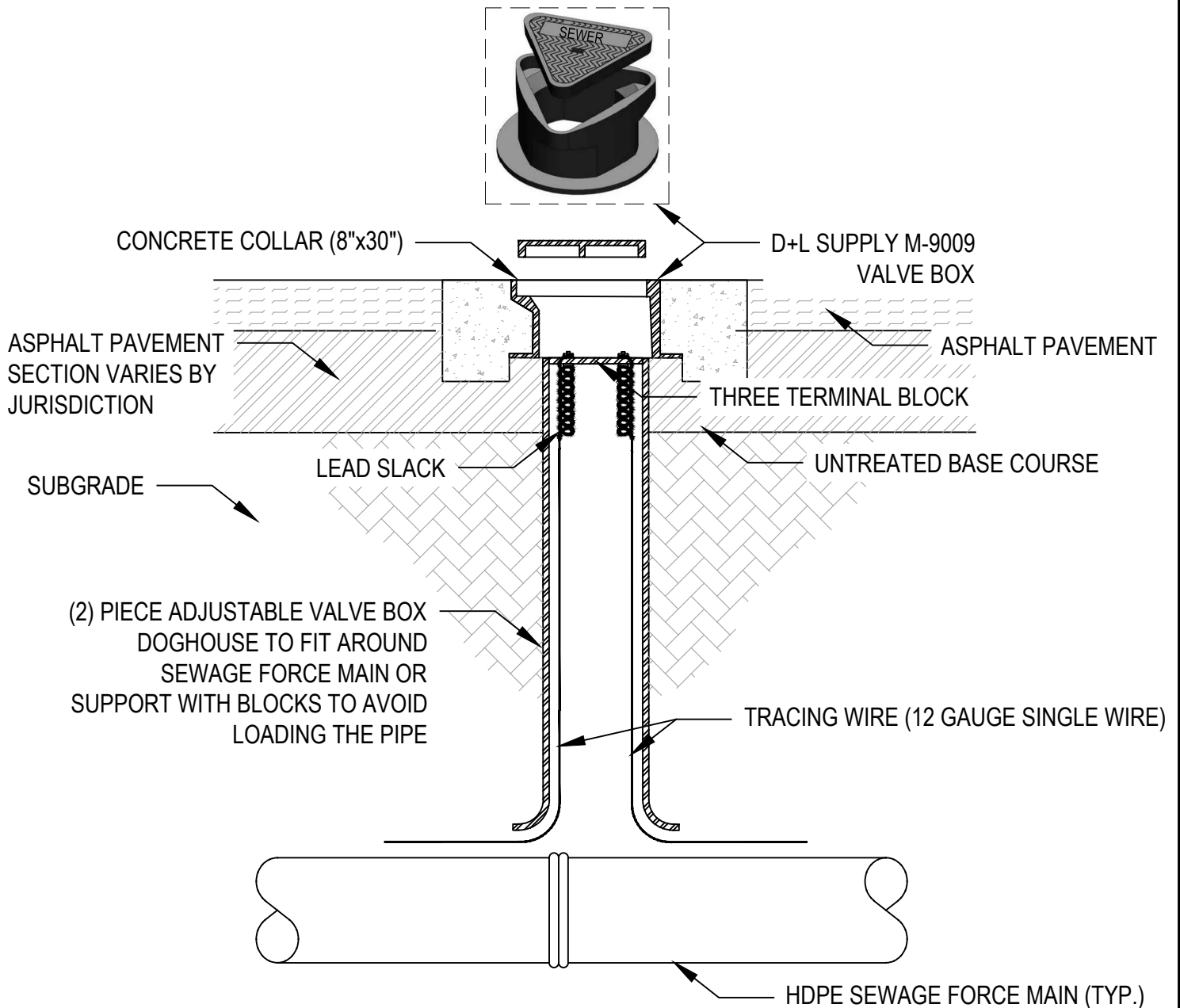

LOCATOR BALLS WILL BE REQUIRED IN EACH MONUMENT AND EVERY 100 FT ALONG THE FORCE MAIN SEWER LINE. IN ADDITION WHEN THERE IS A CHANGE OF DIRECTION HORIZONTAL OR VERTICAL, STARTING 40 FEET BEFORE CHANGE OF DIRECTION LOCATOR BALLS WILL BE REQUIRED EVERY 20 FEET BEFORE AND AFTER THE CURVE. LOCATOR BALLS CAN BE OBTAIN AT THE DISTRICT OFFICE



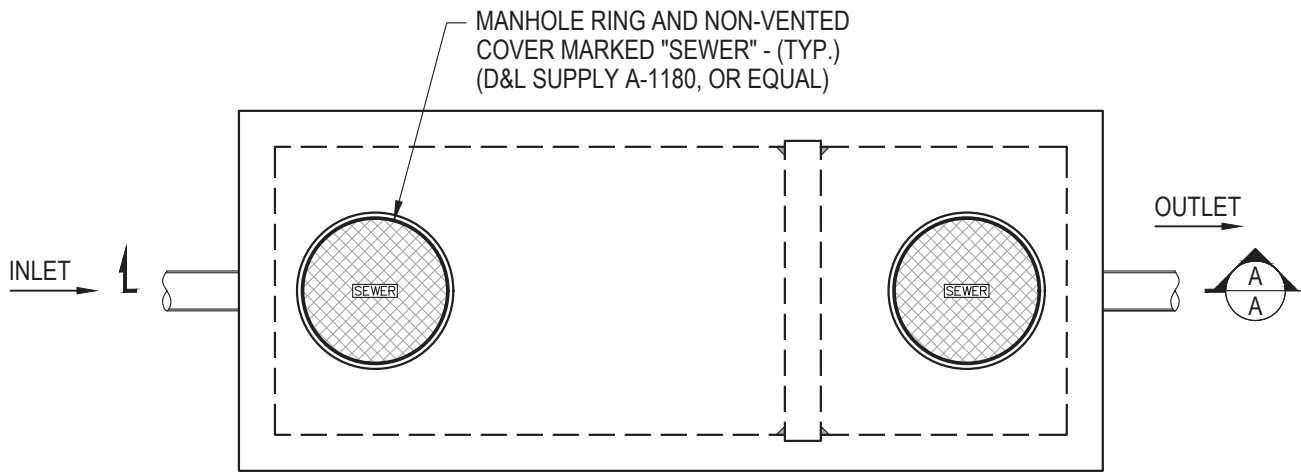

**PLAN VIEW**

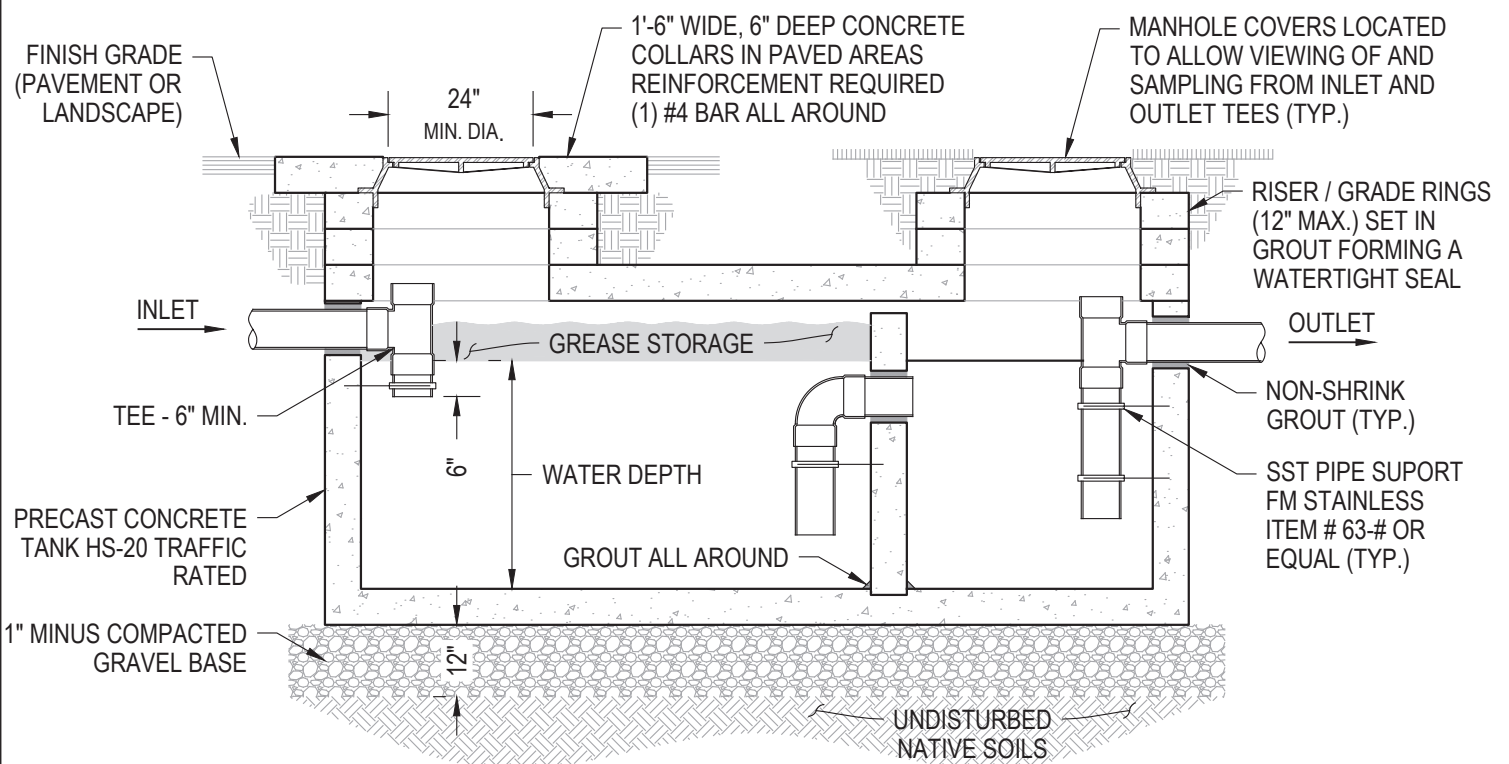

**SECTION VIEW A-A**

**NOTES:**

1. GREASE INTERCEPTOR SHALL BE LOCATED TO BE CONTINUOUSLY AND EASILY ACCESSIBLE FOR INSPECTION AND CLEANING AS CLOSE AS PRACTICAL TO THE SOURCE OF WASTEWATER.
2. WHEN LOCATED IN PAVED AREA, THE TRAP, MANHOLE COVERS, ETC. SHALL BE TRAFFIC RATED.
3. INLET AND OUTLET TEES SHALL BE LOCATED DIRECTLY BELOW MANHOLE ACCESSES.
4. GREASE INTERCEPTOR SHALL HAVE A MINIMUM OF TWO COMPARTMENTS.
5. MINIMUM HYDRAULIC VOLUME OF THE TRAP SHALL BE 750 GALLONS UNLESS OTHERWISE APPROVED BY THE DISTRICT MANAGER.
6. CONTRACTOR SHALL BE RESPONSIBLE FOR PROTECTION OF ALL UTILITIES, PROPER BACKFILLING, COMPACTING, AND PAVEMENT RESTORATION.
7. CONTRACTOR SHALL GUARANTEE WORK FOR A PERIOD OF ONE YEAR.
8. GRADE RINGS SHALL BE GROUTED TO PREVENT INFILTRATION. GROUT SHALL BE FULL STRENGTH, NON-METALLIC, NON-SHRINK TYPE V GROUT (MASTERFLOW 713, FIVESTAR GROUT OR APPROVED EQUAL) WITH ADDITIVES FOR PROTECTION AGAINST HYDROGEN SULFIDE ATTACK.



**CENTRAL DAVIS  
SEWER DISTRICT**

**GREASE INTERCEPTOR**

STANDARD DETAIL

**401**

Revision Date:

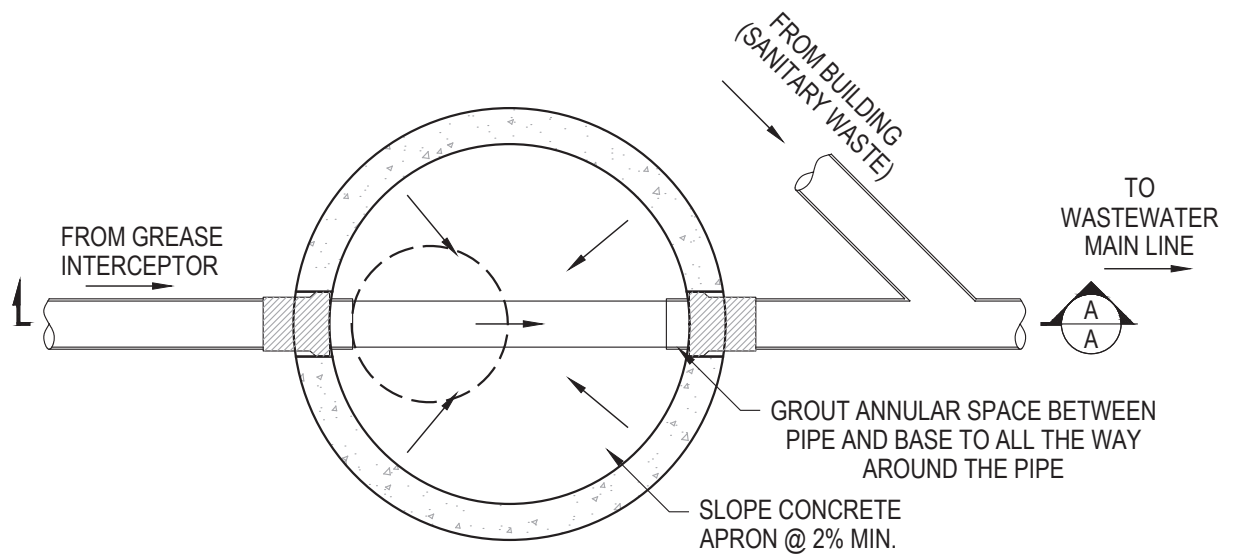

**PLAN VIEW**

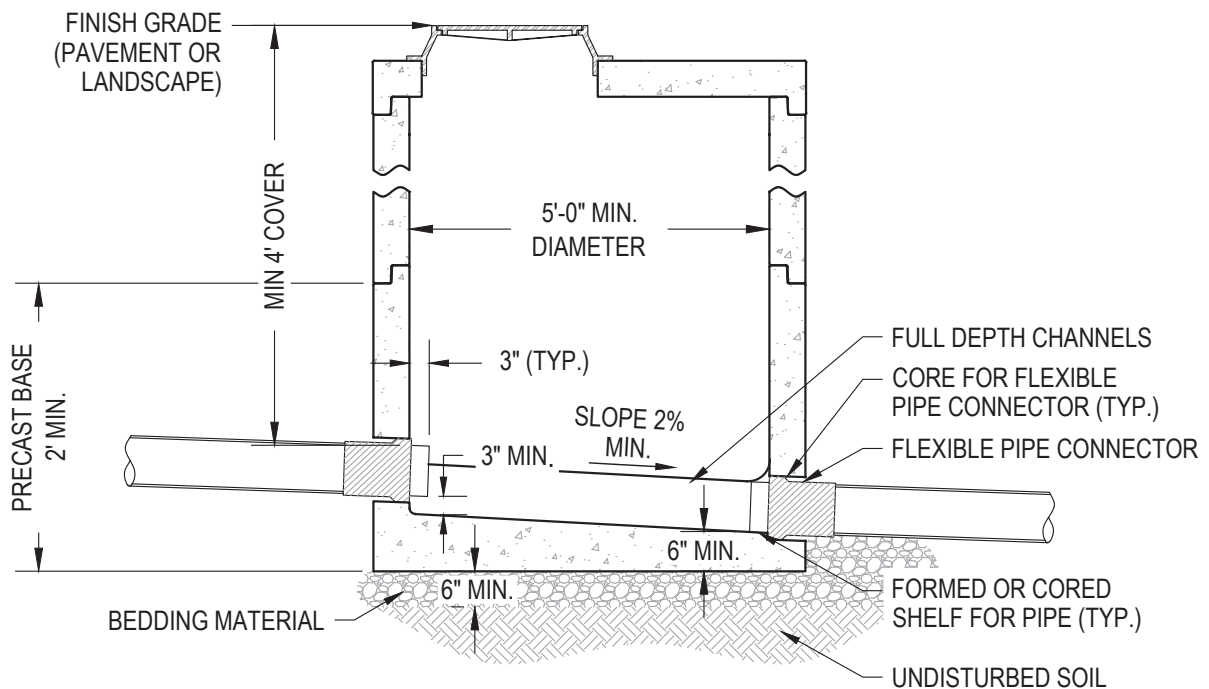

**SECTION VIEW A-A**

**NOTES:**

1. BOTTOM INLET PIPE INTO MANHOLE MUST BE AT LEAST 3-INCHES ABOVE THE BOTTOM OF THE TROUGH AND EXTENDED 3-INCHES BEYOND THE INSIDE OF THE MANHOLE WALL.
2. WIDTH AND DIAMETER OF TROUGH MUST BE THE SAME AS DIAMETER OF INLET PIPE .
3. SANITARY WASTE LINE MUST CONNECT AT LEAST 2- FEET DOWNSTREAM OF SAMPLING MANHOLE.
4. MANHOLE OPENING SHALL BE CENTERED OVER INLET PIPE.



# Grease Interceptor Sizing



**CENTRAL DAVIS SEWER DISTRICT**

Business Name: \_\_\_\_\_  
 Business Address: \_\_\_\_\_  
 Contact: \_\_\_\_\_  
 Days/Hours of Operation: \_\_\_\_\_

Inventory of Kitchen Equipment and Plumbing Fixtures for this Establishment: (Grills, burners, ovens, hoods deep fryers, wok stations, soup kettles, sinks, prewash sinks, dishwasher, mop sink, floor drains etc.)  
 \_\_\_\_\_  
 \_\_\_\_\_

How is waste oil/grease handled, stored and recycled/disposed? \_\_\_\_\_  
 \_\_\_\_\_

- Contact Central Davis Sewer District if you have any questions at 801-451-2190. A Development Review signature approval is required on this form.
- The minimum sized Grease Interceptor permitted is 750 gallons.

	Number of Meals per Peak Hour		Waste Flow Rate		Retention Time		Storage Factor		Calculated Interceptor Size		Approved Grease Interceptor
Enter Calculations > Here	<input type="text"/>	X	<input type="text"/>	X	<input type="text"/>	X	<input type="text"/>	=	<input type="text"/>		<input type="text"/>
	Step 1		Step 2		Step 3		Step 4		Step 5		Step 6

**1**

**Number of Meals Per Peak Hour:**

Seating Capacity	x	Meal Factor	=	Meals per Peak Hour
<input type="text"/>		<input type="text"/>		<input type="text"/>

<b>Establishment Type:</b>	<b>Meal Factor</b>
Fast Food (45 min)	1.33
Restaurant (60 min)	1.00
Leisure Dining (90 min)	0.67
Dinner Club (120 min)	0.50

**Notes:**

\_\_\_\_\_

\_\_\_\_\_

\_\_\_\_\_

\_\_\_\_\_

\_\_\_\_\_

**2**

**Waste Flow Rate:**

<b>Condition</b>	<b>Flow Rate</b>
With a Dishwashing Machine	6 Gallons
Without a Dishwashing Machine	5 Gallons
Single Service Kitchen	2 Gallons
Food Waste Disposer Only	1 Gallon

**Notes:**

\_\_\_\_\_

\_\_\_\_\_

\_\_\_\_\_

\_\_\_\_\_

**3**

**Retention Time**

Commercial Kitchen Waste with Dishwasher	2.5 Hours
Single Service Kitchen or not Dishwasher	1.5 Hours

**Notes:**

\_\_\_\_\_

**4**

**Storage Factor**

Kitchen Type	
Fully Equipped Commercial	
Hours of Operation	
8 Hours	1.0
12 Hours	1.5
16 Hours	2.0
24 Hours	3.0
Single Service Kitchen	1.5

**Notes:**

\_\_\_\_\_

\_\_\_\_\_

\_\_\_\_\_

\_\_\_\_\_

\_\_\_\_\_

**5**

**Calculate Liquid Capacity**

Multiply the values from step 1,2,3 and 4. The result is the approximate grease interceptor size for this application

**Notes:**

\_\_\_\_\_

**6**

**Select Grease Interceptor**

Using the approximate required liquid capacity from step 5, select an appropriate size as recommended by the manufacturer

**Notes:**

\_\_\_\_\_

Size Approved: \_\_\_\_\_ Gallons      Approved by: \_\_\_\_\_      Date: \_\_\_\_\_

Note: The purpose of this worksheet is to assist the business in complying with permit submittal requirements. It is not a complete list of permit or code requirements and should not be used as a substitute for applicable laws and regulations